

ECE413B: Wired Communication

Prepared by:
Engr. Stephanie B. Senomio, MT

1

FooterText

10/18/2024

1

Light Propagation

OPTO-ELECTRONICS AND FIBEROPTICS

2

FooterText

10/18/2024

2

A. Photon Energy:

- **1860: James Clerk Maxwell**
 - theorized **that electromagnetic radiation** contained a series of oscillating waves comprised of an **electric and magnetic field in quadrature (at 90° angle)**
- **1905: Albert Einstein and Max Planck**
 - showed that when **light is emitted or absorbed**, it **behaves like an electromagnetic wave** and also like particle, called **photon**, which possesses energy **proportional to its frequency**.

3

A. Photon Energy:

- This theory is known as **Planck's Law**
 - It describes the **photoelectric effect** w/c states....
 - " when visible light or high-frequency electromagnetic radiation illuminates a metallic surface, electrons are emitted." Emitted electrons produce an electric current.
 - FORMULA

$$E_p = hf$$

Where:

E_p = energy of photon (joules)

h = planck's constant = 6.625×10^{-34} J-s

f = frequency of light (hertz)

4

A. Photon Energy:

- **Example**

- Find the energy of a single photon if the wavelength is $0.8\mu\text{m}$.

5

B. Optical Power:

- Light intensity can be expressed in **Photometric or Radiometric Terms**
- **Photometry** is the science of measuring only light waves that are visible to the human eye.
 - In photometric terms: light intensity is described in terms of luminous flux density and measured in lumens per unit area.
- **Radiometry** measures the light throughout the entire electromagnetic spectrum.
 - In radiometric terms (more useful to engineers and technologists) : optical power measures the rate at which electromagnetic waves transfer light energy.

6

B. Optical Power:

- In simple terms, optical power is described as the flow of light energy past a given point in a specified time.

- Formula:

$$\text{Optical Power (P)} = d(\text{energy})/d(\text{time}) \\ = dQ/Dt$$

- **Where:**

P = optical power (watts)

dQ = instantaneous charge (joules)

dt = instantaneous change in time (seconds)

7

B. Optical Power:

- Optical power is generally stated in decibels relative to a defined power level:

- **Formula:**

- **dbm = $10 \log (P/1\text{mW})$**

- **db μ = $10 \log (P/1 \mu\text{W})$**

- **Example:**

- Determine the optical power in dBm and dB μ for power levels of

a. 10 mW

b. 20 μ W

8

C. Velocity of Propagation:

- The speed of light is approximately 3×10^8 m/s or 186,000 mi/s, in free space (in air or a vacuum)

Note:

- Electromagnetic wave travels slower in materials more dense than free space and that all light frequencies do not propagate at the same velocity.
- When electromagnetic wave passes from a more dense material into a less dense material, the light ray is refracted away from the normal.
- The normal is simply an imaginary line drawn perpendicular to the interface of the two materials at the point of incidence.

9

D. Refraction:

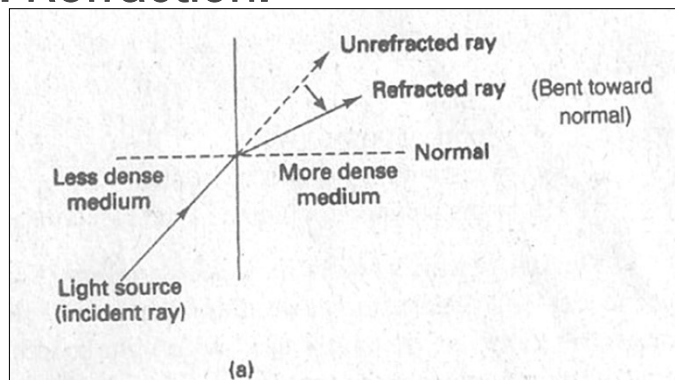

- Figure (a) shows how a light ray is refracted (bent) as it passes from a less dense material into a more dense material.
- (Actually, the light ray is not bent; rather, it changes direction at the interface.)

10

D. Prismatic Refraction:

- The spectral separation of white light

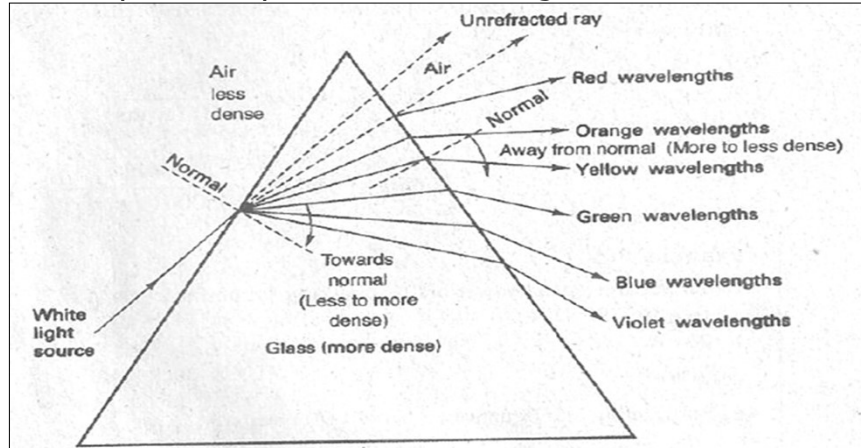

- It shows how sunlight, which contains all light frequencies (white light), is affected as it passes through a material that is more dense than air.

11

E. Refractive Index:

- It is the ratio of the velocity of propagation of a light ray in free space to the velocity of propagation of a light ray in a given material.

- **Formula:**

$$n = c/v$$

where:

n = refractive index (unit less)

c = speed of light in free space (3×10^8 m/s)

v = speed of light in a given material (m/s)

12

E. Refractive Index:

- **TABLE OF TYPICAL INDEXES OF REFRACTION:**

| Material | Index of Refraction |
|------------------|---------------------|
| Vacuum | 1.0 |
| Air | 1.0003 (~ 1) |
| Water | 1.33 |
| Ethyl Alcohol | 1.36 |
| Fused Quartz | 1.46 |
| Glass Fiber | 1.5 - 1.9 |
| Diamond | 2.0 – 2.42 |
| Silicon | 3.4 |
| Gallium-arsenide | 2.6 |

13

F. Snell's Law

- How a **light ray reacts when it meets the interface** of two transmissive materials that have different indexes of refraction can be **explained with Snell's Law**.
- The **angle of incidence** is the angle at which the propagating ray strikes the interface with respect to the normal.
- The **angle of refraction** is the angle formed between the propagating ray and the normal after the ray has entered the second medium.

14

F. Snell's Law

- **Refractive Model for Snell's Law**

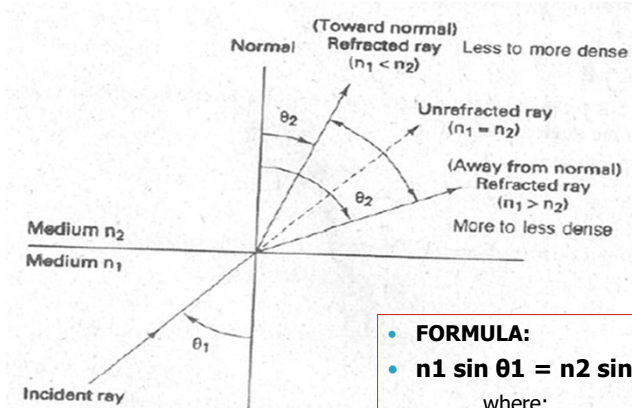

- **FORMULA:**
- **$n_1 \sin \theta_1 = n_2 \sin \theta_2$**
 where:
 n_1 = refractive index of material 1 (unitless)
 n_2 = refractive index of material 2 (unitless)
 θ_1 = angle of incidence (degrees)
 θ_2 = angle of refraction (degrees)

15

F. Snell's Law

- **Light ray refracted away from the normal**

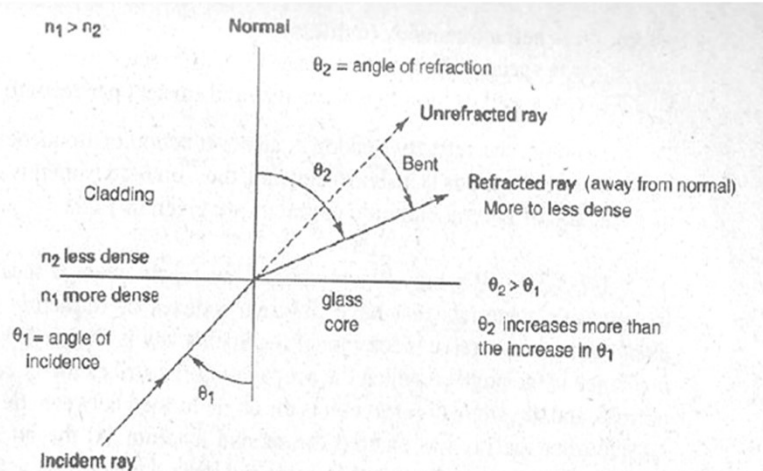

- **Note: Refracted angle is greater than incident angle.**

16

F. Snell's Law

- **EXAMPLE:**

Let medium 1 be glass and medium 2 be ethyl alcohol. For an angle of incidence of 30° , determine the angle of refraction.

17

G. Critical Angle

- Figure (a) shows a condition in which an incident ray is striking the glass/cladding interface at an angle (θ_1) such that the angle of refraction (θ_2) is 90° and refracted ray is along the interface.

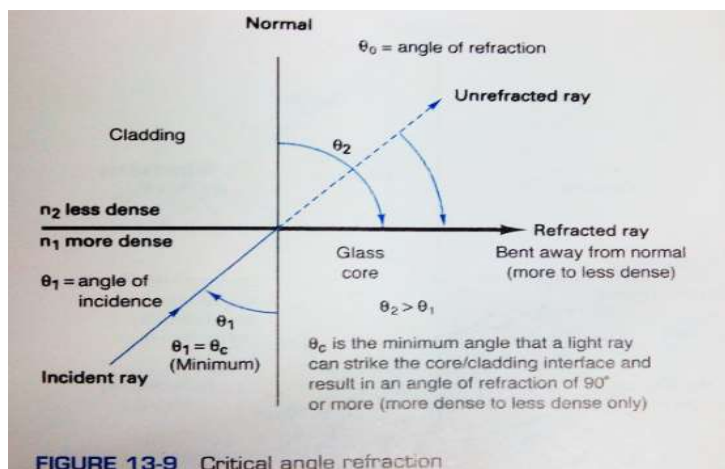

This angle of incidence is called critical angle, w/c is defined as the minimum angle of incidence at w/c a light ray may strike the interface of two media and result in an angle of refraction of 90° or greater.

18

G. Critical Angle

- Light ray must be travelling from medium of higher refractive index to medium w/a lower refractive index (ex.glass into cladding)
- If the angle of refraction is 90° or greater, the light ray is not allowed to penetrate the less dense material.

$$\sin \theta_1 = \frac{n_2}{n_1} \sin \theta_2$$

With $\theta_2 = 90^\circ$, θ_1 becomes the critical angle (θ_c), and

$$\sin \theta_c = \frac{n_2}{n_1}(1) = \sin \theta_c = \frac{n_2}{n_1}$$

and

$$\theta_c = \sin^{-1} \frac{n_2}{n_1}$$

Note:

- It can be seen that critical angle is dependent on the ratio of refractive indexes of the core and cladding

19

G. Critical Angle

- Example:

For a multimode step index fiber with glass core ($n_1 = 1.53$) and a fused quartz cladding ($n_2 = 1.44$), determine the critical angle.

20

H. Acceptance Angle

- This addresses the light-gathering ability of fiber w/c is the ability to couple light from the source into fiber.

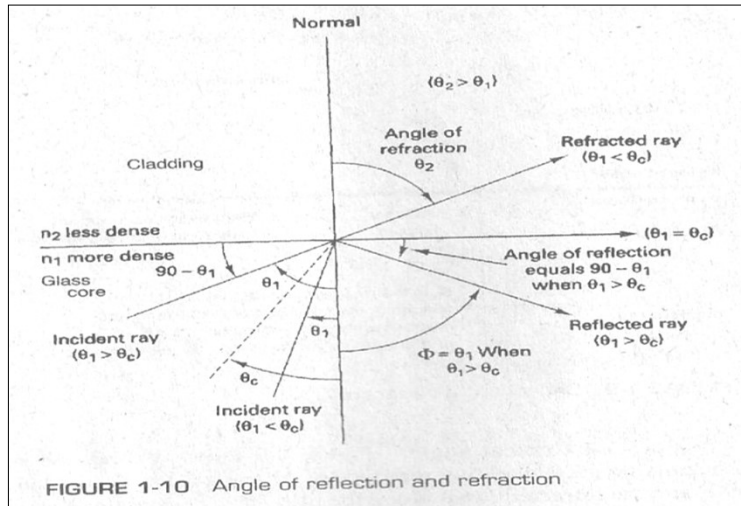

FIGURE 1-10 Angle of reflection and refraction

21

H. Acceptance Angle

- Figure 1-11 shows the source of end fiber cable and a light ray propagating into and then down the fiber.
- When light rays enter the core fiber, they strike the air/glass interface at normal A.
- n of air = approx. 1 and n of glass core = 1.5.,

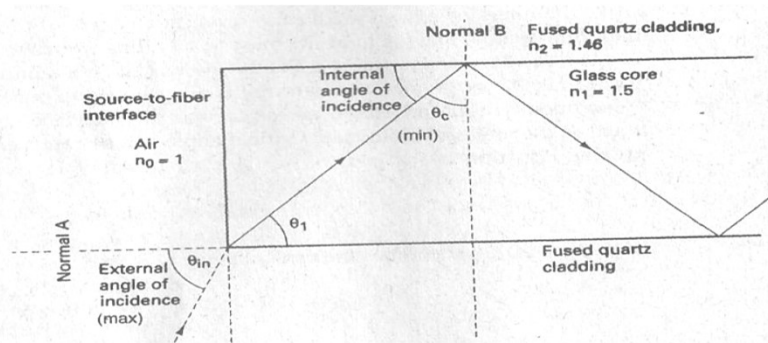

FIGURE 1-11 Ray propagation into and down an optical fiber cable

22

H. Acceptance Angle

- The light enters the cable traveling from a less dense to a more dense medium, causing ray to refract toward normal.
- This causes the light rays to change direction & propagate diagonally down the core at an angle that is less than the external angle of incidence (θ_{in})
- For a ray of light to propagate down the cable, it must strike the internal core/cladding interface at an angle that is greater than the critical angle (θ_c)

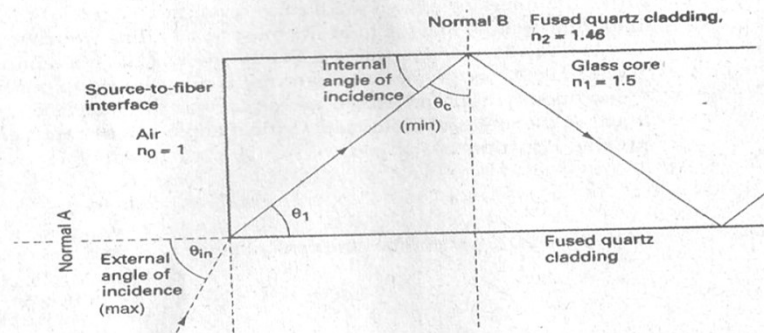

FIGURE 1-11 Ray propagation into and down an optical fiber cable

23

H. Acceptance Angle

- Using Figure 1-12 and Snell's Law, it can be shown that the maximum angle that external light rays may strike the air/glass interface and still enter the core and propagate down the fiber is

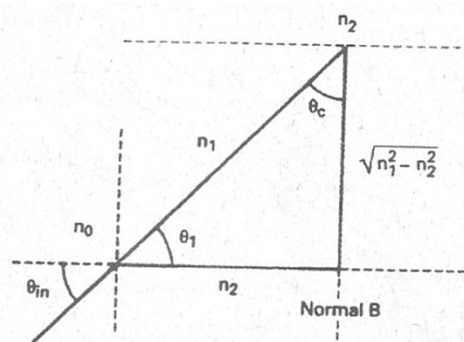

FIGURE 1-12 Geometric relationship of Equations 1-11a and b

24

H. Acceptance Angle

- Using Figure 1-12 and Snell's Law, it can be shown that the maximum angle that external light rays may strike the air/glass interface and still enter the core and propagate down the fiber is

$$\theta_{\text{in(max)}} = \sin^{-1} \frac{\sqrt{n_1^2 - n_2^2}}{n_o} \quad (1-11a)$$

where $\theta_{\text{in(max)}}$ = acceptance angle (degrees)

n_o = refractive index of air (1)

n_1 = refractive index of glass fiber core (1.5)

n_2 = refractive index of quartz fiber cladding (1.46)

Since the refractive index of air is 1, Equation 1-11a reduces to

$$\theta_{\text{in(max)}} = \sin^{-1} \sqrt{n_1^2 - n_2^2} \quad (1-11b)$$

25

H. Acceptance Angle

- **NOTE:**
- $\theta_{\text{in(max)}}$ is called the acceptance angle or acceptance cone half-angle.
- $\theta_{\text{in(max)}}$ defines the maximum angle in w/c external light rays may strike the air/glass interface and still propagate down the fiber.
- Rotating the acceptance angle around the fiber core axis describes the acceptance cone of the fiber input.

26

H. Acceptance Angle

- Acceptance cone is shown in figure a below and the relationship bet. Acceptance angle and critical angle.

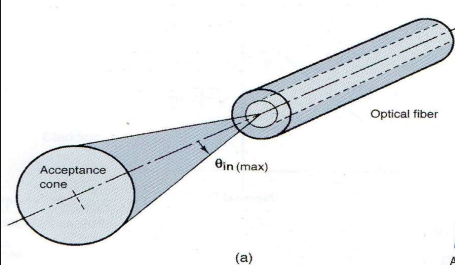

(a)

- Light rays striking the air/glass interface in an angle greater than acceptance angle will enter the cladding and, therefore, will not propagate down the cable.

NOTE

- The critical angle is defined as min. value and the acceptance angle is defined as the max. value.

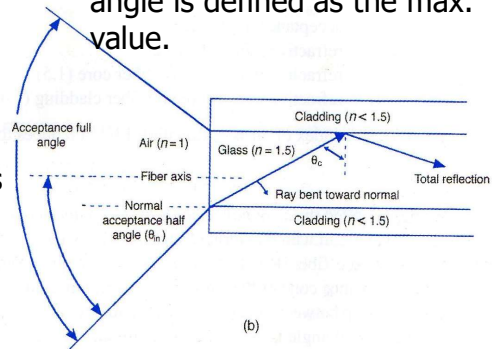

(b)

FIGURE 13-13 (a) Acceptance angle; (b) acceptance cone

27

H. Acceptance Angle

Example

- An optical fiber and its cladding have refractive indexes of 1.55 and 1.32 respectively. Determine the acceptance angle.

28

I. Numerical Aperture

- Is closely related to acceptance angle and is the figure of merit commonly used to measure the magnitude of the acceptance angle.
- In essence, NA is used to describe the light-gathering or light-collecting ability of an optical fiber (i.e. the ability to couple light into the cable from an external source)
- The larger the magnitude of NA, the greater the amount of external light the fiber will accept.
- The NA for light entering the glass fiber from an air medium is described mathematically as...

29

I. Numerical Aperture

and $NA = \sin \theta_{in}$

Therefore $NA = \sqrt{n_1^2 - n_2^2}$

$\theta_{in} = \sin^{-1} NA$

where θ_{in} = acceptance angle (degrees)
 NA = numerical aperture (unitless)
 n_1 = refractive index of glass fiber core (unitless)
 n_2 = refractive index of quartz fiber cladding (unitless)

- A larger-diameter core does not necessarily produce large NA, although in practice large-core fibers tend to have larger NA.
- NA can be calculated using the given equations but in practice it is generally measured by looking at the output of a fiber because the light-guiding properties of a fiber cable are symmetrical.
- Therefore, light leaves a cable and spreads out over an angle equal to the acceptance angle.

30

I. Numerical Aperture

Example

- An optical fiber and its cladding have refractive indexes of 1.55 and 1.32 respectively. Determine the numerical aperture.

31

J. Optical Fiber Configuration:

- **a.) Mode of Propagation**
- SINGLE MODE – there is only one path for light rays to take.
- MULTIMODE – there is more than one path for light rays to take.

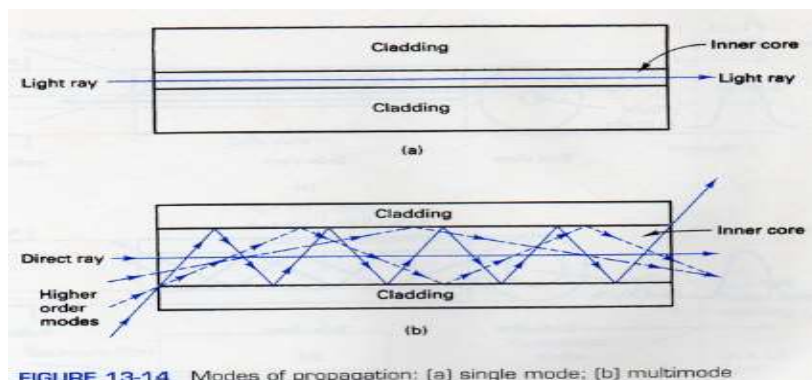

FIGURE 13-14 Modes of propagation: [a] single mode; [b] multimode

32

J. Optical Fiber Configuration:

- The no. of paths(modes) possible for a multimode fiber cable depends on the frequency (wavelength) of the light signal, the refractive indexes of the core and cladding, and the core diameter.
- Mathematically, the no. of modes possible for a given cable can be approximated by the ff. formula:

$$N \approx \left(\frac{\pi d}{\lambda} \sqrt{n_1^2 - n_2^2} \right)^2$$

where N = number of propagating modes
 d = core diameter (meters)
 λ = wavelength (meters)
 n_1 = refractive index of core
 n_2 = refractive index of cladding

33

J. Optical Fiber Configuration:

b.) Index Profile

- It is the graphical representation of the magnitude of the refractive index across the fiber.
- The refractive index is plotted on the horizontal axis, and the radial distance from their core axis is plotted on the vertical axis.
- TWO BASIC TYPES:
 - 1. step-index
 - 2. graded-index

34

J. Optical Fiber Configuration:

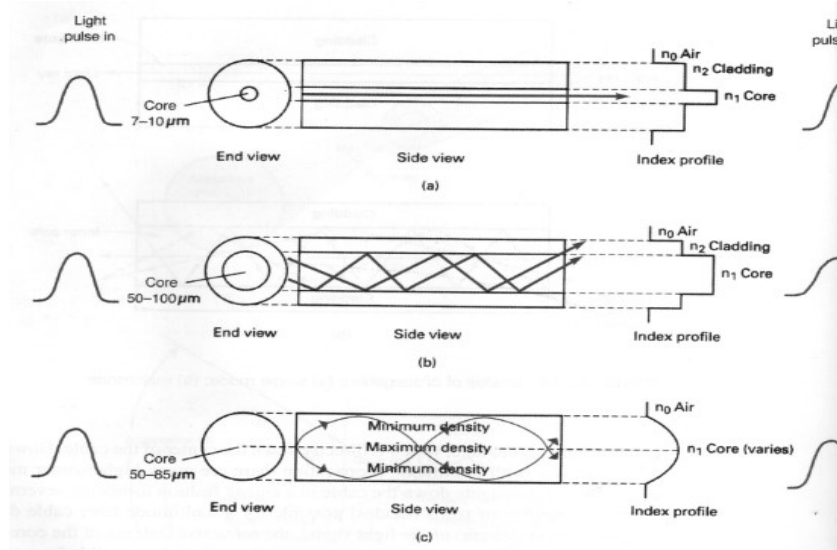

35

K. Optical Fiber Classification:

a. Single-Mode Step-Index Optical Fiber

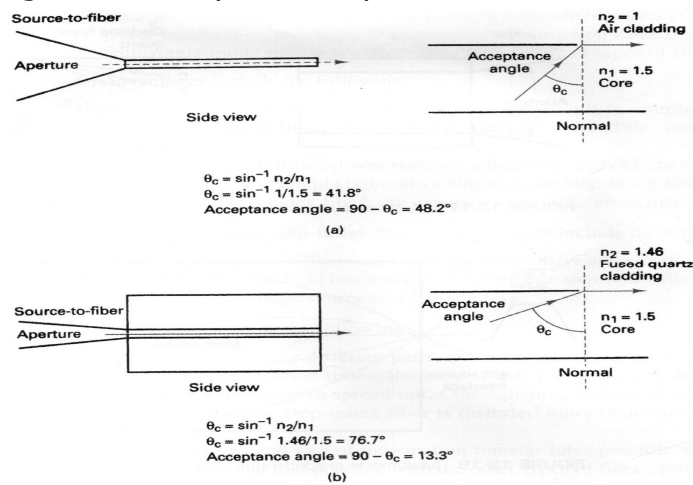

FIGURE 13-16 Single-mode step-index fibers: (a) air cladding; (b) glass cladding

36

K. Optical Fiber Classification:

b. Multi-Mode Step-Index Optical Fiber

c. Multi-Mode Graded-Index Optical Fiber

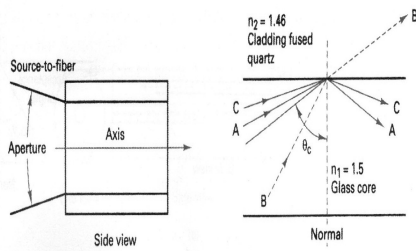

FIGURE 13-17 Multimode step-index fiber

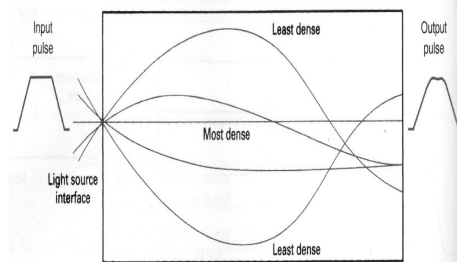

FIGURE 13-18 Multimode graded-index fiber

37

Fiber Optic Losses

OPTO-ELECTRONICS AND FIBEROPTICS

38

Power Loss or Attenuation

- Power loss is often called **attenuation** and results in **reduction in the power** of the light wave as it travels down the cable.
- It has adverse effect on performance...
 - reducing system's BW
 - reducing information transmission rate
 - Reducing efficiency and overall system capacity

39

Power Loss or Attenuation

- FORMULA

$$A_{(dB)} = 10 \log (P_{out}/P_{in})$$

Where:

- $A_{(dB)}$ = total reduction in power level
= or attenuation (unitless)
 P_{out} = cable output power (Watts)
 P_{in} = cable input power (Watts)

- In general, **multimode fibers** tend to have **more attenuation** than single modes cables because of the increased scattering of the light wave produced from the dopants in the glass.

40

Power Loss or Attenuation

- Optical power in watts measured at a given distance from a power source can be determined mathematically as...
 - FORMULA

$$P = P_t \times 10^{-AI/10}$$

Where:

- P = measured power level (watts)
- P_t = transmitted power level (watts)
- A = cable power loss (dB/km)
- l = cable length (km)

41

Power Loss or Attenuation

- The optical power in decibel units is...
 - FORMULA

$$P(\text{dBm}) = P_{\text{in}}(\text{dBm}) - AI(\text{dB})$$

Where:

- P = measured power level (dBm)
- P_t = transmitted power level (dBm)
- A = cable power loss (dB/km)
- l = cable length (km)
- AI = attenuation (dB)

42

Power Loss or Attenuation

- **Percent Output Power vs. Loss in dB**

| LOSS (dB) | OUTPUT POWER (%) |
|-----------|------------------|
| 1 | 79 |
| 3 | 50 |
| 6 | 25 |
| 9 | 12.5 |
| 10 | 10 |
| 13 | 5 |
| 20 | 1 |
| 30 | 0.1 |
| 40 | 0.01 |
| 50 | 0.001 |

43

Power Loss or Attenuation

- **Fiber Cable Attenuation**

| Cable Type | Core Diameter (μm) | Cladding Diameter (μm) | NA (unitless) | Attenuation (dB/km) |
|--------------|--------------------|------------------------|---------------|---------------------|
| Single Mode | 8 | 125 | -- | 0.5 at 1300 nm |
| | 5 | 125 | -- | 0.4 at 1300 nm |
| Graded Index | 50 | 125 | 0.2 | 4 at 850 nm |
| | 100 | 140 | 0.3 | 5 at 850 nm |
| Step Index | 200 | 380 | 0.27 | 6 at 850 nm |
| | 300 | 440 | 0.27 | 6 at 850 nm |
| PCS | 200 | 350 | 0.3 | 10 at 790 nm |
| | 400 | 550 | 0.3 | 10 at 790 nm |
| Plastic | - | 750 | 0.5 | 400 at 650 nm |
| | - | 1000 | 0.5 | 400 at 650 nm |

44

Power Loss or Attenuation

Example:

- For a single-mode optical cable with 0.25-dB/km loss, det. the optical power 100 km from a 0.1-mW light source.

$$\begin{aligned}P &= 0.1\text{mW} \times 10^{-[(0.25)(100)]/(10)} \\&= 1 \times 10^{-4} \times 10^{[(0.25)(100)]/(10)} \\&= (1 \times 10^{-4})(1 \times 10^{-2.5}) \\&= 0.316 \mu\text{W} \\P(\text{dBm}) &= 10 \log\left(\frac{0.316 \mu\text{W}}{0.001}\right) \\&= -35 \text{ dBm}\end{aligned}$$

$$\begin{aligned}P(\text{dBm}) &= 10 \log\left(\frac{0.1 \text{ mW}}{0.001 \text{ W}}\right) - [(100 \text{ km})(0.25 \text{ dB/km})] \\&= -10 \text{ dBm} - 25 \text{ dB} \\&= -35 \text{ dBm}\end{aligned}$$

45

Predominant Losses in Optical Fiber Cables are the following:

- A. Absorption Loss
- B. Material, or Rayleigh, Scattering Losses
- C. Chromatic, or Wavelength, Dispersion
- D. Radiation Losses
- E. Modal Dispersion
- F. Coupling Losses

46

A. Absorption Loss

- It is analogous to **power dissipation in copper cable**;
- Impurities in fiber absorb the light and convert it to **heat**.
- The **ultrapure glass** used to manufacture optical fibers that is approximately 99.9999% pure.
- Still, absorption losses between **1 dB/km & 1000 dB/km** are typical.

- 3 Factors that contribute to absorption losses:
 - a. Ultraviolet Absorption
 - b. Infrared Absorption
 - c. Ion Resonance Absorption

47

a. Ultraviolet Absorption

- It is caused by valence electrons in the silica material from which the fibers are manufactured.

- Light ionizes the valence electrons into conduction.

- The ionization is equivalent to a loss in the total light field and, consequently, contributes to the transmission losses of the fiber.

48

b. Infrared Absorption

- It is the result of photons of light that are absorbed by the atoms of the glass core molecules.
- The absorbed photons are converted to random mechanical vibrations typical of heating.

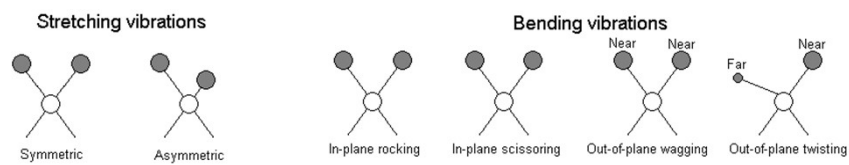

49

c. Ion Resonance Absorption

- Caused by OH^- ions in the material.
- The ions are water molecules that are trapped in the glass during the manufacturing process.
- Iron, copper and chromium molecules also cause ion absorption

50

Absorption Losses in Optical Fiber

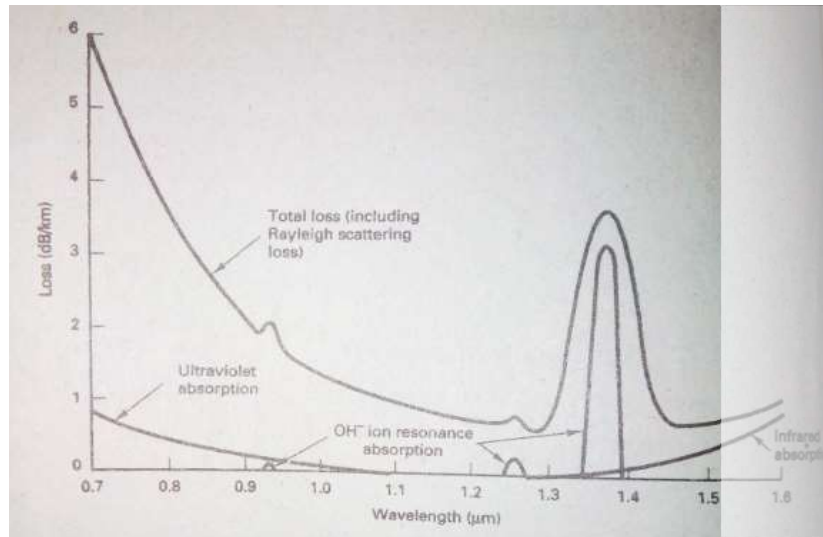

51

B. Material or Rayleigh Scattering Losses

- During manufacturing, glass is drawn into fibers of very **small diameter** & in a **plastic** state (not liquid & not solid)
- The tension applied to the glass causes the cooling glass to develop permanent submicroscopic irregularities .
- When light rays strike the impurities they are diffracted these are called **Rayleigh Scattering Loss**.
- Diffraction causes the light to disperse or spread out in many directions. (some continues down the fiber & some escape through the cladding)

52

C. Chromatic or Wavelength Dispersion

- It occurs when non-coherent light sources where light contains combination of different wavelengths.
- The different wavelengths have different velocities therefore do not arrive at the receiver at the same time.
- It can be eliminated by using a monochromatic source.
- It can occur only in single mode of transmission.

53

D. Radiation Loss

- Radiation Loss are predominantly caused by small bends and kinks in the fiber.

Two Types:

1. Microbends

- A microbend is a miniature bend or geometric imperfection along axis of the fiber which represents the discontinuity in the fiber.
- Microbending occurs as a result in differences in the thermal contraction rates between the core and the cladding material.
- Small scale bending

2. Constant-Radius Bends

- These are caused by excessive pressure and tension and generally occur when fibers are bent during handling/ installation.
- Large bends

54

E. Modal Dispersion

- Also known as pulse spreading.
- It is caused by the difference in the propagation times of light ray that take different path down a fiber.
- It can occur only in multimode fibers.
- It can reduced considerably by using graded index fibers and almost entirely eliminated by using single-mode step-index fibers.

55

E. Modal Dispersion

- In multimode propagation, dispersion is often expressed as BANDWIDTH DISTANCE PRODUCT (BDP) or BANDWIDTH LENGTH PRODUCT (BLP)
- BLP indicates what signal frequency can be propagated through a given distance of fiber cable.
- BLP is expressed mathematically as the product of distance and bandwidth (sometimes called linewidth)
- BLP are often expressed in MHz-km units.
- As the length of an optical cable increases, the BW decreases in proportion.

56

E. Modal Dispersion

Example:

- For a 300-meter optical cable with a BLP of 600 MHz-km, determine the BW.

- Solution:

$$B = \frac{600 \text{ MHz-km}}{0.3 \text{ km}}$$

$$\mathbf{B = 2 \text{ GHz}}$$

57

F. Coupling Losses

- Coupling Losses are caused by imperfect connection.
- Losses that occur in some types of optical junctions: Light-Source-to-Fiber, Fiber-to-Fiber, and Fiber-to-photodetector connections.
- Junction losses are most often caused by one or more of the following alignment problems:
 - a. Lateral Misalignment
 - b. Gap Misalignment
 - c. Angular Misalignment
 - d. Imperfect Surface Finish

58

a. Lateral Displacement (misalignment)

- It is the lateral or axial displacement between two pieces of adjoining fiber cables
- The amount of loss can be from a couple tenths of a decibel to several decibels
- It is negligible if the fiber axes are aligned to w/in 5% of the smaller fiber's diameter.

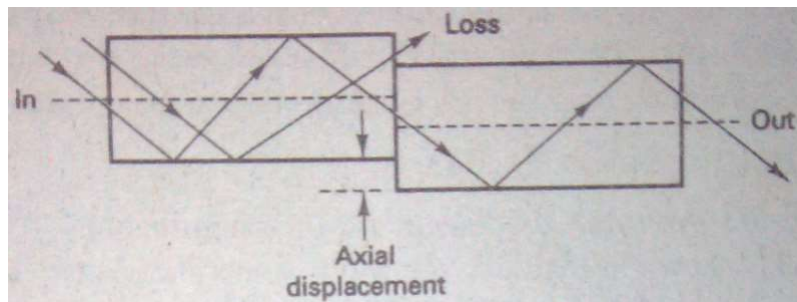

59

b. Gap Displacement (misalignment)

- Also called end separation.
- The fiber should actually touch; the farther apart the fibers, the greater the loss of light.
- If the two fibers are joined w/a connector, the end should not touch because the two ends rubbing against each other in the connector could cause damage to either or both fibers.

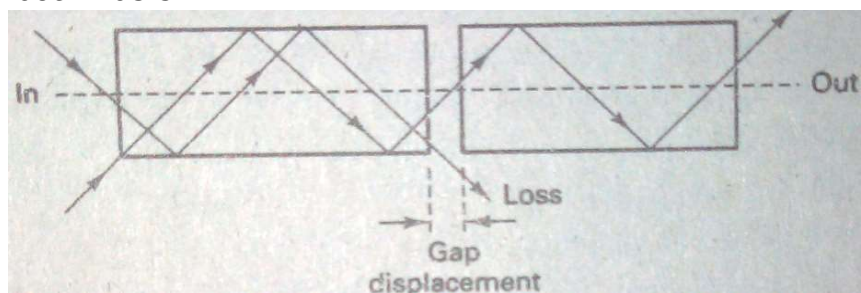

60

c. Angular Displacement (misalignment)

- If the angular displacement is less than 2° , the loss will typically be less than 0.5dB.

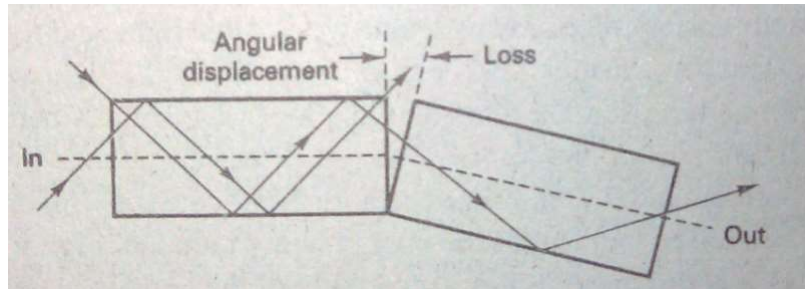

61

d. Imperfect Surface Finish

- The ends of the two adjoining fibers should be highly polished and fit together squarely.
- If the fiber ends are less than 3° off from the perpendicular, the losses will typically be less than 0.5 dB.

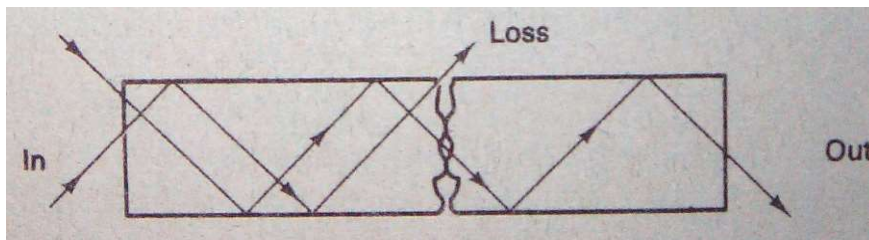

62

SONET

(Synchronous Optical Network)

OPTO-ELECTRONICS AND FIBEROPTICS

63 FooterText 10/18/2024

63

SONET

- SONET was developed by **American National Standard's Institute (ANSI)**
- SDH was developed by **Comite Consultif International de Telegraphique et Telephonique (CCITT)**
- (Consultative Committee for International Telephony and Telegraphy)
- Now...**International Telecommunications Union – Telecommunications Services Sector (ITU-T).**

64

SONET

- SONET contains recommendations for the standardization of **Fiber Optic Transmission System (FOTS)** equipment sold by different manufacturers.
- its physical specifications and frame design include mechanisms that allow it to carry signals from incompatible tributary systems (such as DS-0 and DS-1)

65

SONET/SDH Rates

| <i>STS</i> | <i>OC</i> | <i>Rate (Mbps)</i> | <i>STM</i> |
|------------|-----------|--------------------|---------------|
| STS-1 | OC-1 | 51.840 | |
| STS-3 | OC-3 | 155.520 | STM-1 |
| STS-9 | OC-9 | 466.560 | STM-3 |
| STS-12 | OC-12 | 622.080 | STM-4 |
| STS-18 | OC-18 | 933.120 | STM-6 |
| STS-24 | OC-24 | 1244.160 | STM-8 |
| STS-36 | OC-36 | 1866.230 | STM-12 |
| STS-48 | OC-48 | 2488.320 | STM-16 |
| STS-96 | OC-96 | 4976.640 | STM-32 |
| STS-192 | OC-192 | 9953.280 | STM-64 |

66

- Each synchronous transfer signal *STS-n* is composed of 8000 frames. Each frame is a two-dimensional matrix of bytes with 9 rows by $90 \times n$ columns.

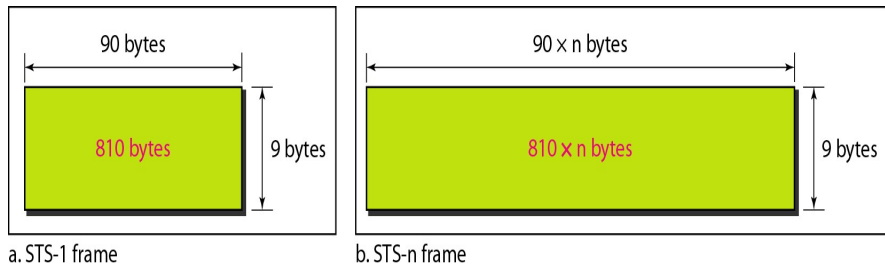

67

Sonet Frame

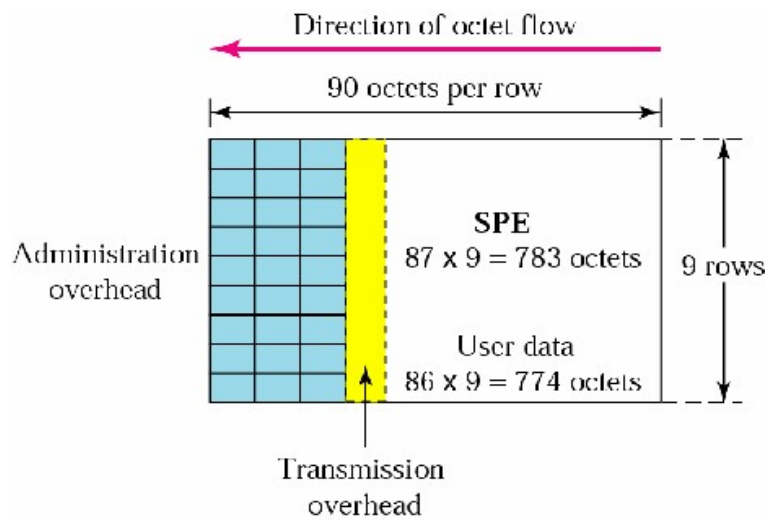

68

Frames in Transmission

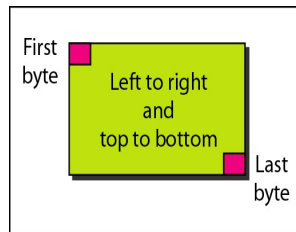

a. Byte transmission

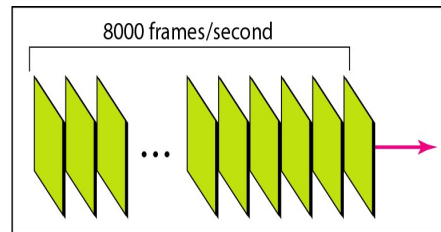

b. Frame transmission

A SONET STS-n
signal is transmitted at
8000 frames per second.

Each byte in a SONET frame
can carry a digitized voice
channel.

69

Sample Problem

- Find the data rate of an STS-1 signal.

Solution

STS-1, like other STS signals, sends 8000 frames per second. Each STS-1 frame is made of 9 by (1 × 90) bytes. Each byte is made of 8 bits. The data rate is

$$\text{STS-1 data rate} = 8000 \times 9 \times (1 \times 90) \times 8 = 51.840 \text{ Mbps}$$

70

Overheads

- allows simpler multiplexing and greatly expanded OAM&P (Operation, Administration, Maintenance and Provisioning) capabilities.
- **Path-level overhead** is carried from end-to-end
- **Line overhead** is for the STS-N signal between STS-N multiplexers
- **Section overhead** is used for communications between adjacent network elements such as regenerators

71

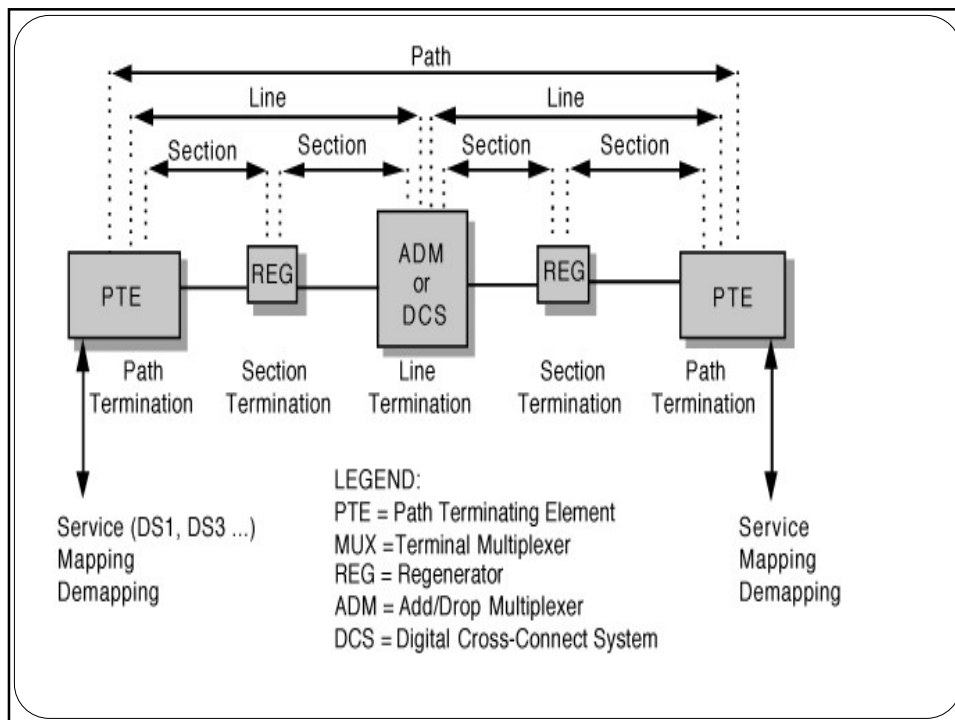

72

Sample Problem

- *What is the user data rate of an STS-1 frame (without considering the overheads)?*

Solution

The user data part in an STS-1 frame is made of 9 rows and 86 columns. So we have

$$\text{STS-1 user data rate} = 8000 \times 9 \times (1 \times 86) \times 8 = 49.536 \text{ Mbps}$$

73

SONET

- it is a good example of **TDM or Time Division Multiplexing system**. The bandwidth of the fiber is considered as one channel divided into time slots to define sub channels.
- SONET as a TDM network is a synchronous system controlled by a master clock with a very high level of accuracy.

74

TIME DIVISION MULTIPLEXING

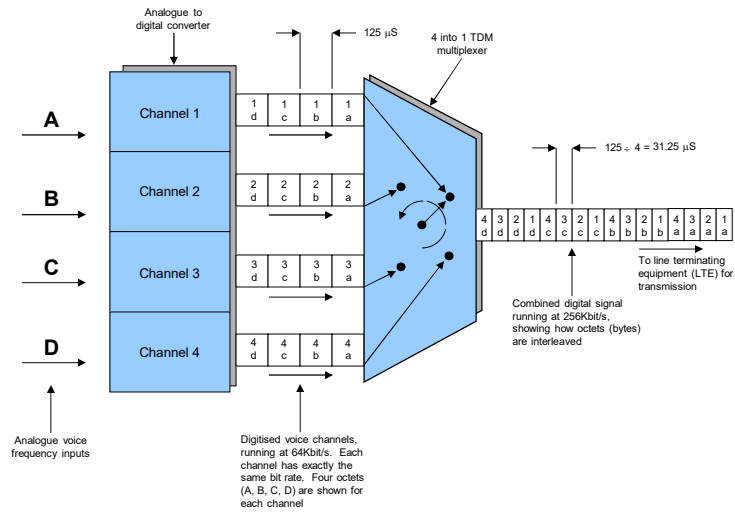

75

Sample of a SONET Network

ADM: Add/drop multiplexer
 STS MUX: Synchronous transport signal multiplexer
 STS DEMUX: Synchronous transport signal demultiplexer

R: Regenerator
 T: Terminal

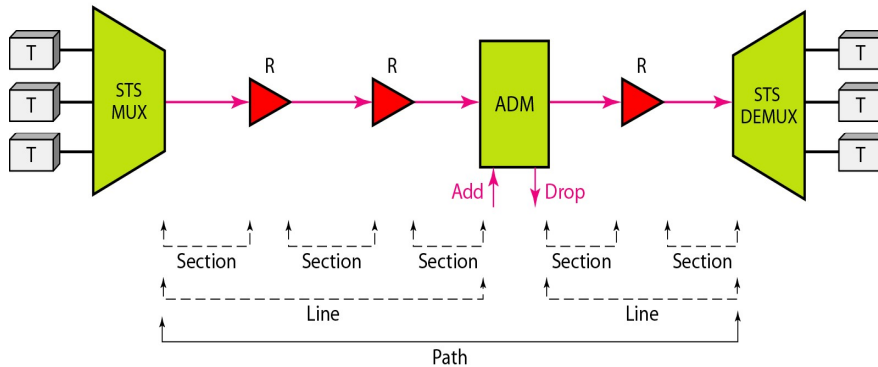

76

SONET Devices

- **STS Multiplexer/Demultiplexer**

Either multiplexes signals from multiple sources into an STS or demultiplexes an STS into different destination signals.

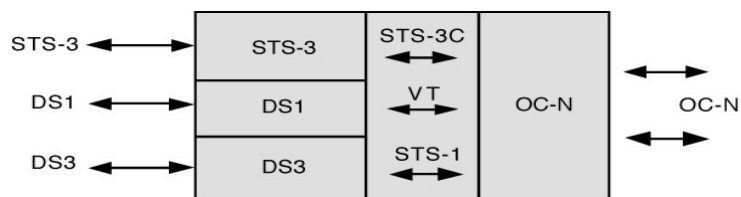

Note: OC = Optical Carriers

77

- **Regenerator**

Replaces some of the existing overhead information (header information) with new information (functions at the data link layer)

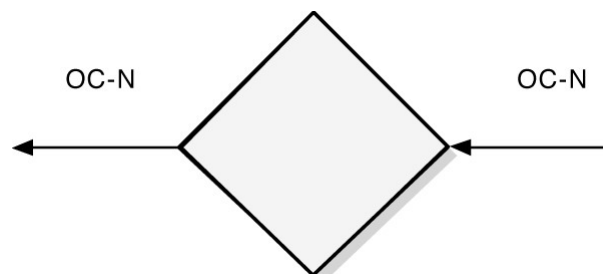

78

- **Add/Drop Multiplexer**

- Can add signals coming from different sources into a given path or remove a desired signal from path and redirect it without demultiplexing the entire signal.

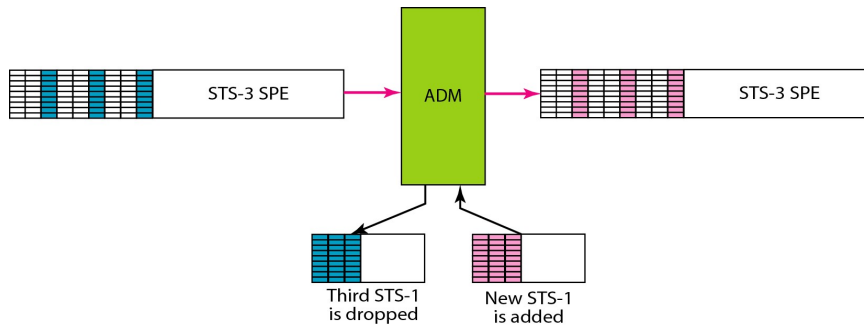

79

Wideband Digital Cross-connects

– may be used to interconnect a much larger number of STS-1s

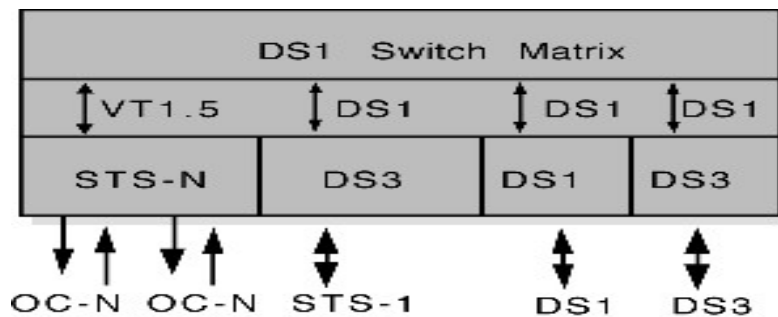

80

Broadband Digital Cross-connects

– can be used for grooming (consolidating or segregating) of STS–1s or for broadband traffic management.

- Wider BW but many channel or frequency used.

81

• Digital Loop Carrier

– a system of multiplexers and switches designed to perform concentration from the remote terminals to the community dial office and to the CO.

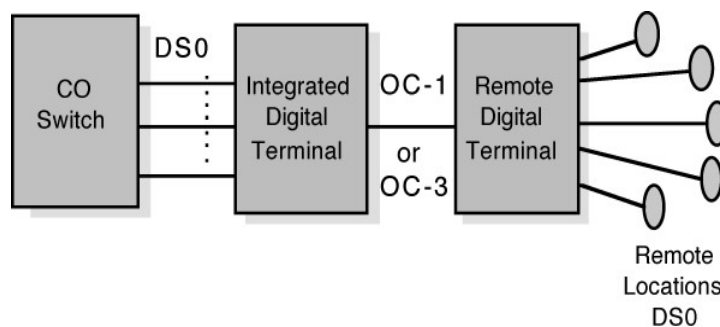

82

SONET/SDH Rates

- **SONET** defines a hierarchy of signaling levels called Synchronous Transport Signals (STs). Each STS level supports a certain data rate.
- **OC or the Optical Carriers** are physical links defined to carry each level of STS. OC levels describe the conceptual and physical specifications of the links required to support each level of signaling.

83

Pointers

- SONET uses a concept called pointers to compensate for frequency and phase variations
- They allow the transparent transport of synchronous payload envelopes (either STS or VT) across boundaries such as nodes with separate network clocks

84

Virtual Tributaries

- SONET is designed to carry broadband payloads.
- Current digital hierarchy data rates, however, are lower than STS-1.
- To make SONET backward-compatible with the current hierarchy, its frame design includes a system of virtual tributaries (VTs).
- A virtual tributary is a partial payload that can be inserted into an STS-1.

85

Virtual Tributaries

VT1.5 = 8000 frames/s 3 columns 9 rows 8 bits = 1.728 Mbps
VT2 = 8000 frames/s 4 columns 9 rows 8 bits = 2.304 Mbps
VT3 = 8000 frames/s 6 columns 9 rows 8 bits = 3.456 Mbps
VT6 = 8000 frames/s 12 columns 9 rows 8 bits = 6.912 Mbps

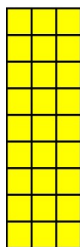

VT1.5

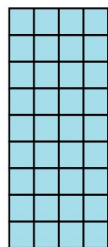

VT2

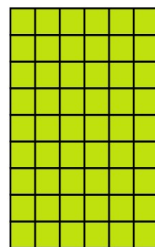

VT3

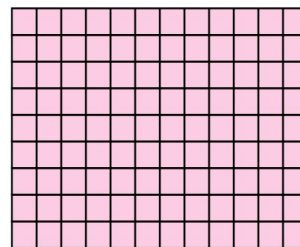

VT6

86

SONET Multiplexing

- For example, three STS-1 signals (channels) can be combined into one STS-3 signal (channel), four STS-3s can be multiplexed into one STS-12, and so on.

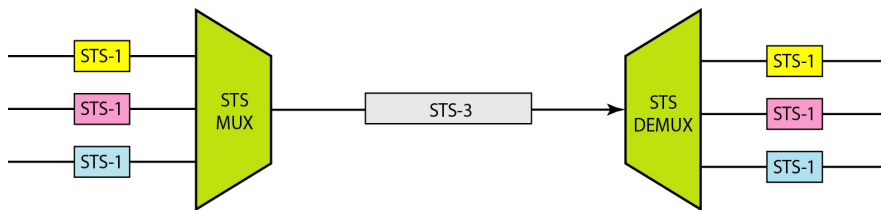

87

Sonet multiplexing

Byte interleaving

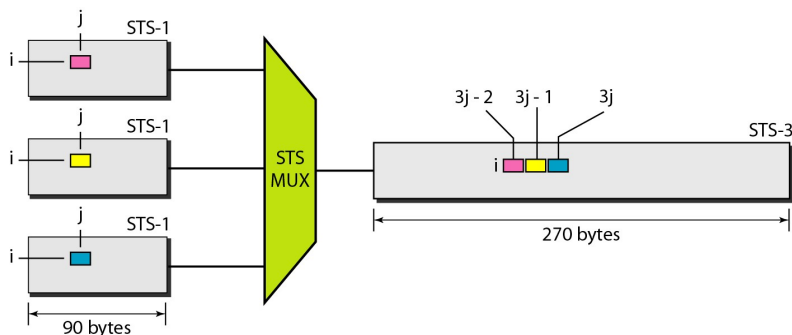

88

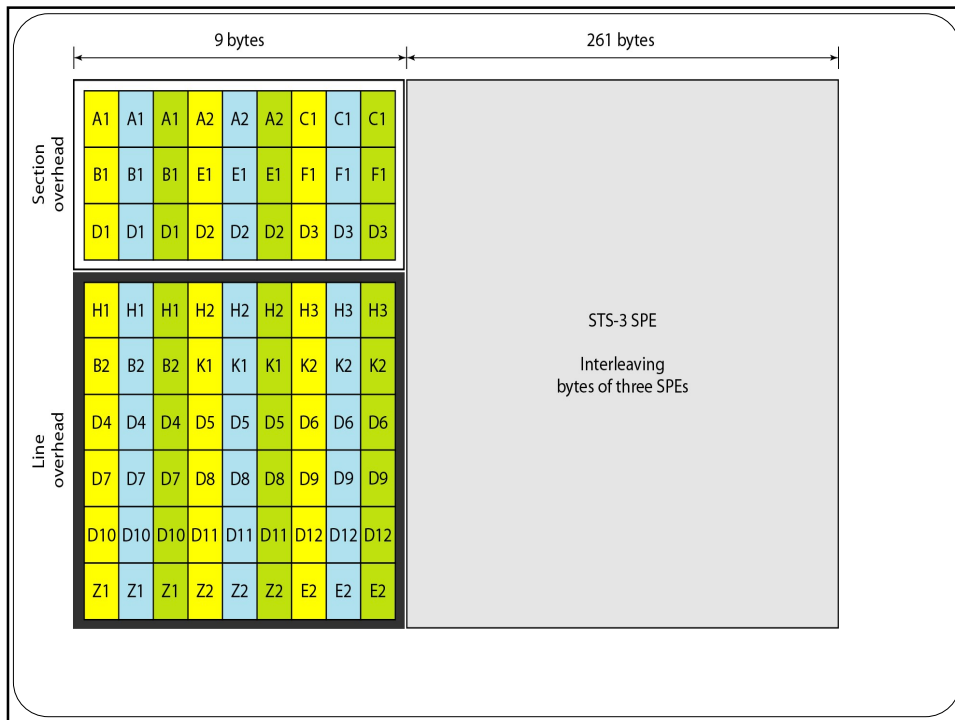

89

Sonet network

- **Point-to-Point**

- In this configuration the SONET path and the service path are identical and this synchronous island can exist within an asynchronous network world.

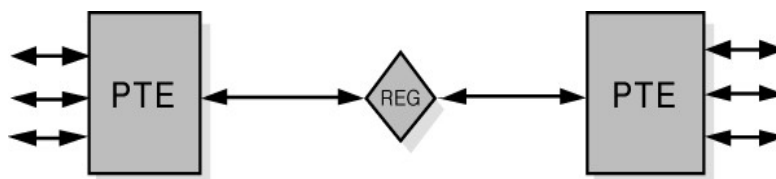

90

Sonet network

• Point-to-Multipoint

- A point-to-multipoint architecture includes adding and dropping circuits along the way.
- The ADM (add/drop multiplexer) is typically placed along a SONET link to facilitate adding and dropping tributary channels at intermediate points in the network

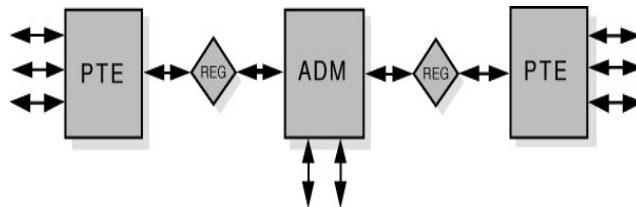

91

Sonet Network

• Hub Network

- The hub network architecture accommodates unexpected growth and change more easily than simple point-to-point networks.
- A hub concentrates traffic at a central site and allows easy re-provisioning of the circuits.

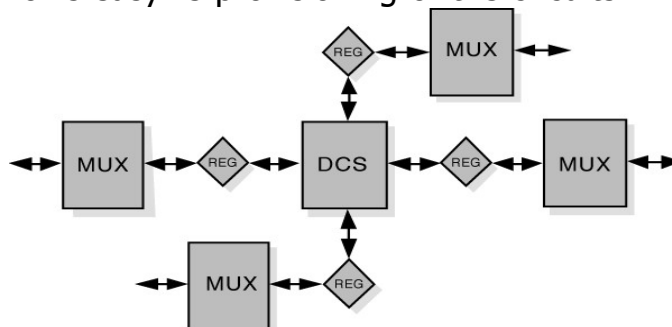

92

Sonet Network

- **Ring Architecture**

- The SONET building block for a ring architecture is the ADM
- The main advantage of the ring topology is its survivability... if a fiber cable is cut, the multiplexers have the intelligence to send the services affected via an alternate path through the ring without interruption
- The demand for survivable services, flexibility to rearrange services to alternate serving nodes, as well as automatic restoration within seconds, have made rings a popular SONET topology

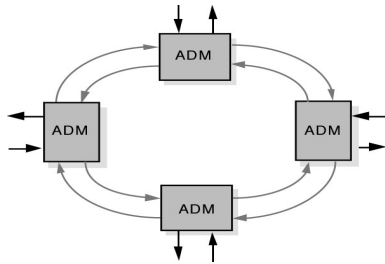

93

SONET SAMPLE ARCHITECTURE

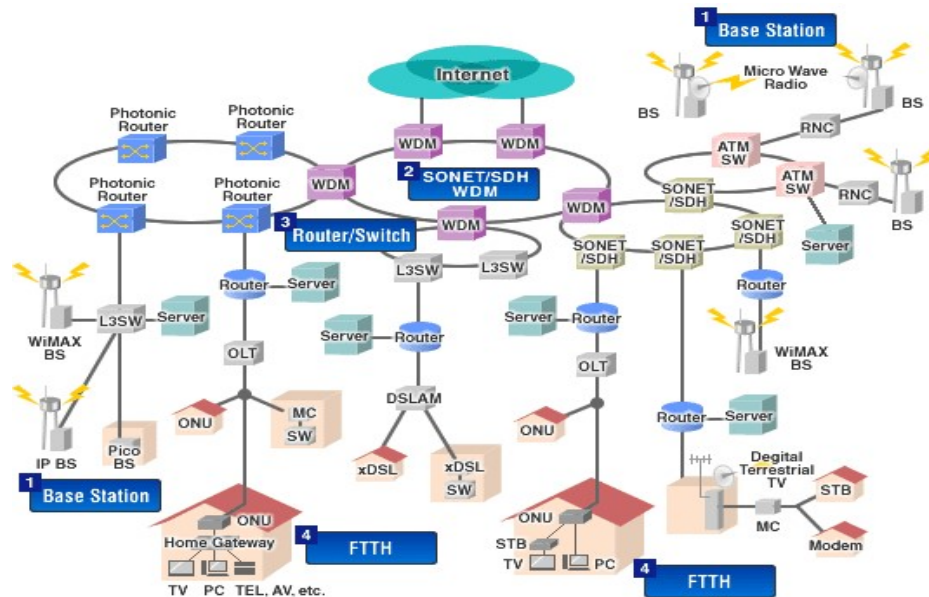

94