

RESEARCH AREAS IN SPACE



RESPOND

CAPACITY BUILDING & PUBLIC OUTREACH (CBPO)

Indian Space Research Organisation
Bengaluru

May 2025



RESEARCH AREAS IN SPACE

**A Document for
Preparing
Research Project Proposals**

RESPOND & AI

Capacity Building & Public Outreach (CBPO)
ISRO-HQ, Bengaluru

May 2025

Technical Guidance

Shri. G Harikrishnan, Director, CBPO, ISRO HQ

Dr. M A Paul, Associate Director, RESPOND & AI, CBPO, ISRO HQ

Technical Support and Compilation

Shri Nishant Kumar, Deputy Director, CBPO, ISRO HQ

Smt Nirupama Tiwari, Deputy Director, CBPO, ISRO HQ

Shri M Uday Kumar, Programme Manager, CBPO, ISRO HQ

For any queries please contact

Shri. G Harikrishnan

Director, Capacity Building & Public Outreach (CBPO)

Indian Space Research Organisation HQ

Department of Space

Government of India

Antariksh Bhavan

New BEL Road

Bangalore 560094

Dr. M A Paul

Associate Director, RESPOND & AI, CBPO

Indian Space Research Organisation HQ

Department of Space

Government of India

Antariksh Bhavan

New BEL Road

Bangalore 560094

E-mail: respond@isro.gov.in

भारतीय अंतरिक्ष अनुसंधान संगठन

अंतरिक्ष विभाग

भारत सरकार

अंतरिक्ष भवन

न्यू बी ई एल रोड, बेंगलूरु - 560 094, भारत

दूरभाष : +91-80-2341 5241 / 2217 2333

फैक्स : +91-80-2341 5328



Indian Space Research Organisation

Department of Space

Government of India

Antariksh Bhavan

New BEL Road, Bengaluru - 560 094, India

Telephone: +91-80-2341 5241 / 2217 2333

Fax : +91-80-2341 5328

e-mail : chairman@isro.gov.in

secydos@isro.gov.in

डॉ. व. नारायणन / Dr. V. Narayanan

अध्यक्ष

Chairman

Message

ISRO undertakes research and development of launch vehicles, satellite and applications for meeting the societal needs. Towards this, ISRO actively fosters partnerships with industry and academia to advance space research and technology development. The ISRO–Academia partnership is one of the important pillars in India's space research ecosystem, designed to foster innovation, indigenous technology development and skill-building. It helps to bridge the gap between fundamental research and mission-driven engineering. As ISRO unveils the Research Areas in Space – 2025, reaffirming ISRO's commitment to fostering a research environment that is forward-looking, inclusive and aligned with the dynamic needs of the nation and the evolving global space landscape.



The "**Research Areas in Space - 2025**" document details the organization's current and forthcoming research and development priorities. It is the aggregation of various research domains and serves as a blueprint for academic institutions aiming to align their research endeavours with ISRO's strategic objectives. From building robust and efficient launch systems to advancing satellite platforms that support critical communication, navigation and remote sensing services, to expanding our capabilities in planetary exploration and deep space science - the research agenda is both ambitious and grounded in practical national imperatives.

Catering to the Space Vision 2047, this document comprises of six major research areas Launch Vehicles, Satellite Technology, Human Space Flight Centre, Earth Observation, Space Sciences, Space Policy and management. The Research Areas in Space - 2025 document is not merely a technical reference - it is an invitation to researchers, scholars, engineers, entrepreneurs and students to contribute meaningfully to India's space journey. It calls upon our scientific community to think boldly, act responsibly and innovate with purpose. Together, let us chart new paths, unlock new knowledge and build a spacefaring future that uplifts every citizen and reflects the aspirations of our nation.

May 04, 2025

(डॉ. वी. नारायणन / Dr. V. Narayanan)

भारतीय अन्तरिक्ष अनुसंधान संगठन

अन्तरिक्ष विभाग

भारत सरकार

अन्तरिक्ष भवन

न्यू बी ई एल रोड, बेंगलूरु - 560 094, भारत

दूरभाष : +91 80 2341 6356

फैक्स : +91 80 2341 5298



Indian Space Research Organisation

Department of Space

Government of India

Antariksh Bhavan

New BEL Road, Bengaluru - 560 094, INDIA

Tel (Off) : +91 80 2341 6356

Fax : +91 80 2341 5298

E-mail : scientificsecretary@isro.gov.in

एम. गणेश पिल्लै / M. Ganesh Pillai

वैज्ञानिक सचिव, इसरो / Scientific Secretary, ISRO

Preface

The "Research Areas in Space - 2025" document represents a pivotal step in advancing India's space exploration and technology development, building upon the legacy of the Indian Space Research Organisation (ISRO) and its comprehensive vision for harnessing space for national and global benefit. As a successor to the "Research Areas in Space - 2023" document, this edition encapsulates ISRO's evolving priorities, emerging technological paradigms, and the growing role of academia and industry in shaping the future of space research.



In 2025, ISRO continues to champion innovation in space science, technology, and applications, aligning with its mission to address national needs while contributing to global scientific advancement. This document serves as a guiding framework for academic institutions and researchers, particularly through ISRO's **Space Technology Cells (STCs)** and **Regional Academic Centres for Space (RAC-S)** and **Space Technology Incubation Centres (STICs)**. It outlines critical research domains—spanning Launch Vehicle technology, Satellite Technology, human spaceflight, earth observations and space-science—that are poised to drive ISRO's ambitious programs, including Gaganyaan, Chandrayaan-4 & 5, Next Generation Launch Vehicle, Venus Orbiter Mission and Bhartiya Antariksh Station.

The dynamic landscape of space research demands collaborative efforts to tackle complex challenges from sustainable space operations to cutting-edge remote sensing and artificial intelligence applications. By fostering partnerships with premier academic institutions and encouraging innovative proposals, ISRO aims to catalyze transformative solutions that align with its programmatic goals. This document not only highlights current and upcoming R&D requirements but also underscores ISRO's commitment to nurturing a vibrant ecosystem of scientific inquiry and technological excellence. The execution of R&D projects at academic institutions and engaging students in these projects can be a stepping stone towards their future engagements with Indian Space Programme.

We invite professors, researchers, scientists, and technologists to engage with the opportunities outlined herein, contributing to India's journey toward becoming a global leader in space exploration and technology. Together, we can unlock the vast potential of space to address pressing challenges on Earth and beyond.

April 30, 2025

(एम. गणेश पिल्लै/ M. Ganesh Pillai)

General Instructions

1. **“Research Areas in Space”** is a comprehensive document highlighting ISRO’s major programmes, current and upcoming R&D requirements of ISRO. This document will exclusively cater to the advanced research requirements of ISRO wherein Space Technology Cells (STCs), Regional Academic Centre for Space (RAC-S) and Space Technology Incubation Centres (S-TICs) established at various IITs/NITs and premier institutes across the country can select and generate R&D proposals. The faculty of these institutes are encouraged to submit their project proposals in these diverse research areas.
2. To enable the faculty to prepare suitable proposals of relevance to space programme, a detailed list of R & D areas /sub areas/topics and a brief write up about the topic have been given in this document.
3. The concerned ISRO/DOS centre interested in the research topic is given in brackets after the areas/sub areas/problems.
4. In the case of STC’s the proposals are invited only from the faculty of the same institute and it is to be submitted to the convener of STC’s only. Whereas, in the case of RAC-S/STIC, the faculty from any academic institute of the concerned region can also submit the proposals to the Coordinators of RAC-S and STIC’s based on the call for proposals by the respective institutes (list of RAC-S/STIC coordinators provided in Annexure-4 & 5). Further, the submitted proposals will be subjected to critical evaluation by ISRO/DOS Centres. The proposal will be evaluated on the basis of novelty, methodology, approach, deliverables, experience of the PI in the subject area, duration of the project, budget etc.
5. The Projects having envisaged outcome as a product or process of business/commercial potential shall be submitted through S-TICs.
6. The evaluation reports of the proposals received from the ISRO/DOS centres will be further reviewed by the Joint Policy Committee (JPC) of STC, Joint Policy Management Council (JPMC) of RAC-S and Joint Management Committee (JMC) of S-TICs before its recommendation for funding support.
7. The age limit for the Principal Investigator is below 65 years (sixty-five) including the project period.
8. One hard copy and a soft copy of the proposal shall be submitted to the respective STCs/ RAC-S/ S-TICs.
9. “Application for Grant of Funds including the project proposal” and “Form-C” shall be submitted in the prescribed formats only. Formats are given in the Annexure -1 & 2.
10. Conveners of STC/RAC-S/S-TICs shall submit a soft copy of the proposal to the respective ISRO/DOS centre. The addresses and e-mail ids of Respond Coordinators of respective ISRO/ DOS centres are given in Annexure -3.
11. For any other information kindly visit ISRO
<https://www.isro.gov.in/academia.html>

CONTENTS

Sl. No.	Programmes and Areas	Page No
Launch Vehicle		
A.	Mechanisms for Extra-terrestrial Missions	1-1
B.	Structural Dynamics	1-3
C.	Design of Launch Vehicle. AI, Machine learning	3-3
D.	Materials and Manufacturing	3-5
E.	Propellants, Polymers and Chemicals	5-12
F.	Energy System	12-13
G.	Formal Verification	13-13
H.	Model-based Software Development Framework	13-13
I.	Sensing Systems	14-14
J.	Radio Sounding system development for Planetary Ionospheric	14-14
K.	Superconductor based Electromagnetic Cage	14-15
L.	Avionics-Communication Systems	15-15
M.	Superconductor based electromagnetic field generator for gravity generation	15-15
N.	Aerospace Engineering	15-17
O.	Aerodynamics	17-19
P.	Propulsion	19-19
Q.	Aerothermal	19-20
R.	Photonic Thruster	20-20
S.	Range Operations	21-24
T.	Solid Motor Performance & Environmental Test Facility	24-24
U.	Vehicle Assembly and Launch Facilities	24-24
V.	Liquid Propulsion	25-27
W.	Advanced Propulsion Systems and Control Electronics	27-29
X.	Sensors & Transducers for Liquid Propulsion	29-31
Y.	Materials & Manufacturing for Liquid Propulsion Systems	31-34
Human Space Programme		
A.	Human Research, Space Medicine and Space Biology	35-40
B.	Microgravity Research	40-42
C.	Human Spaceflight & Advanced Technology	42-55
Satellite Technology		
A.	SATCOM and Navigation Payloads	57-85
B.	Satcom & Satnav Applications & Associated Technologies	85-117
C.	Antenna Systems	117-119
D.	Electro-Optical Sensor Technology	119-150
E.	Microwave Remote Sensors	150-160
F.	Signal & Image Processing & Data Product	160-167

G.	Electronics & Microelectronics Design, Fabrication & Testing Technologies	167-183
H.	Semiconductor Technology for Microelectronics Design	184-184
I.	Mechanical Engineering Systems	184-203
J.	Systems Reliability and Safety	203-209
K.	Cyber Services & Information Technology	209-214
L.	Mission Control	214-218
M.	Communication and Power Area	218-221
N.	NavIC Ground Segment Related Research Works	221-222
O.	Radar Systems	222-231
P.	Satellite Communications/Spacecraft Operations	231-231
Q.	Satellite Communications/Electro-Optical Sensor Technology	231-231
Earth Observations		
A.	Geoscience	233-242
B.	Geospatial Data portals and Information Science	242-246
C.	Urban Planning and Urban Climate Studies	246-248
D.	Signal & Image Processing & Data Product	249-256
E.	Atmospheric Science and its applications	256-259
F.	Physical Oceanography (Development of Blue Economy)	259-261
G.	Geophysical Parameters and Applications	261-263
H.	Marine Biology and Ecosystem	263-264
I.	Development of Applications Techniques	264-267
J.	Applications of Remote Sensing in Agriculture, Forestry & Ecosystem	267-273
K.	Air quality, Atmospheric Trace gases and Aerosols	273-276
L.	Aerial Remote Sensing using UAV	276-277
M.	Atmospheric Dynamics and Coupling	277-278
N.	Weather and Climate	278-281
O.	Signal and Data Processing	281-281
P.	Radar and Lidar Instrumentation for Atmospheric Probing	281-283
Q.	Calibration and Validation	283-284
Space Sciences		
A.	Space Situational Awareness	285-290
B.	Planetary Geology	290-291
C.	Planetary Science, Astrobiology, SAR Remote Sensing	291-296
D.	Space and Atmospheric Sciences	296-300
E.	Solar Physics	300-304
F.	Astronomy & Astrophysics	304-308
G.	Space Instrumentation	308-316
H.	Laboratory Study of Astro Materials	316-317
I.	Study of terrestrial analogues of Moon and Mars	317-317
J.	Payloads for upcoming planetary missions	317-318
K.	Geosciences	318-325

L.	Atomic, Molecular and Optical Physics	325-327
M.	Emerging Areas In Theoretical Physics	327-330
N.	Weather and Climate	330-331
O.	Astronomy & Astrophysics	331-332
P.	Space Instrumentation	332-335
Q.	Emerging Areas in Theoretical Physics	335-336
R.	Space weather	336-336
S.	Satellite Remote Sensing of Earth and Planetary Atmosphere	337-338
T.	Design and Development of Quadrupole Mass Spectrometer	338-338
U.	Development of CNT based nonwoven fabric sheet	339-339
SPACE POLICY & MANAGEMENT		
A.	Space Policy and Economy	341-342
B.	Space Insurance	342-343
C.	Management	343-347
D.	Artificial Intelligence for Education	347-348
	Annexure-1	349-353
	Annexure-2	354-355
	Annexure-3	356-358
	Annexure-4	359-359
	Annexure-5	360-360

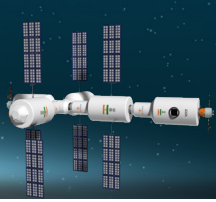

LAUNCH VEHICLE

A	Area	Mechanisms for Extra-terrestrial Missions (VSSC)
A1	Sub Area	Percussive Penetration Mechanisms (VSSC)
A1.1		<p>Design and development of percussion based penetration mechanism for near zero gravity environments (VSSC)</p> <p>For extracting relevant sub surface scientific information from Moon, Mars, Asteroids etc., probes with sensors have to be inserted into the soil of the planetary body. (Similar to ChaSTE in Chandrayaan 3). When conventional penetration mechanisms are used, the weight of the lander in the planet limits reaction force available and thereby limiting the depth of penetration. In such cases, Percussion based penetration systems can be used to penetrate deeper, while limiting the reaction load. This is done by introducing a counter mass, percussion mass and springs to the system, in addition to the probe mass. The system exhibits dynamic behaviour, and continuous stroke of probe can be achieved with much lower reaction.</p> <p>The objective of the research work is to model the system and arrive at the configuration of the systems, for various gravity environments and demonstrate it in horizontal or near horizontal orientation in earth. The model should also take into consideration the force exerted by the planetary soil on the probe.</p>
B	Area	Structural Dynamics (VSSC)
B1	Sub Area	Structural Dynamics and Vibration Control (VSSC)
B1.1		<p>Design and Development of Microgravity Active Vibration Isolation System (MAVIS) for Space Station Experimental Payloads (VSSC)</p> <p>Research platforms employed on-board the space station for conducting microgravity experiments are very sensitive to vibrations caused by space station activities. MAVIS is an active isolation system for the research platforms from these disturbances.</p> <p>The proposed system is a basic demonstration of an Active Vibration Isolation System (AVIS), which will be suitably scaled up further to suit the requirements of research platforms being used for space station. The AVIS consists of a base platform and a payload platform, which are connected by means of suitable motors/actuators, isolators and precision accelerometers as shown in the figure below. A suitable control strategy to be adopted for the design of the controller to limit (1/10 times) the vibration disturbances reaching the payload platform in the frequency range of 1-25 Hz. The experiment is planned to demonstrate on a laboratory level.</p>
B2	Sub Area	Finite Element Code Development (VSSC)
B2.1		<p>Dynamic Response of LV structures under impact loading (VSSC)</p> <p>The proposal aims to get the code for carrying out the dynamic response analysis due to impact loading. Structures considered will be composite, nanocomposite and sandwich</p>

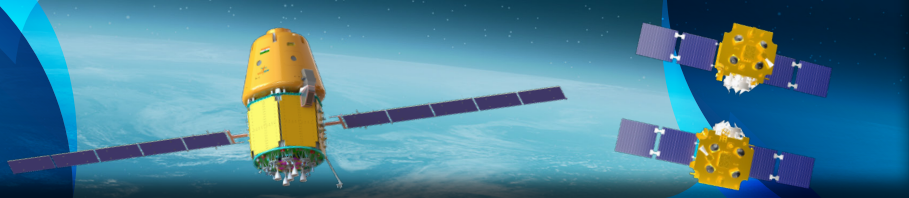

structures. Material deformation and failure to be included. Code to carry out the analysis is expected to be delivered as part of the project. Code to be validated with the existing experimental results or new experiments may be carried out to validate the results.

Software should include following material models (but may not be limited to)

- Elastic material model with Failure
- Elastoplastic material model with Failure
- Orthotropic material model with Failure
- Fiber Composite material model with Failure
- Anisotropic Plastic Material model with Failure
- Piecewise Linear Plasticity model with Failure
- Crushable Orthotropic material model with Failure
- Mooney-Rivlin Rubber Model with failure
- Foam Material (Polypropylene)
- Foam Material with Hysteresis

Software should include following models (but may not be limited to)

- Constant Modulus Shear Model
- Linear Viscoelastic Shear Model
- Polynomial Shear Model
- Hydrodynamic Yield Model
- Mohr-Coulomb Yield Model
- Von Mises Yield Model
- Johnson – Cook Yield Model
- Tanimura-Mimura Yield Model
- Zerilli-Armstrong Yield Model
- Rate Power Law Yield Model
- Polynomial Yield Model
- Steinberg – Guinan Yield Model

Software should include following Material Failure (but may not be limited to)

- Max Plastic strain failure model
- Max Equivalent Stress and Minimum Time Step Failure Model
- Jhonson-Cook Failure Model
- Max Equivalent Stress Failure Model

<p>B2.2</p>	<p>Topology Optimization of Launch Vehicle Structures (VSSC)</p> <p>Using topology optimization launch vehicle structures can be optimized for minimum mass meeting frequency constraint. Also optimum fiber orientation and varying ply thickness can be achieved through this methodology for composite structure. This proposal involves to develop the methodology of topology optimization for ply optimisation and perform dynamic response analysis</p> <p>Software should be able to solve following problems (These problems are only for validation. Software should be General purpose for Topology Optimization)</p> <ul style="list-style-type: none"> • Discrete Fiber Angle Optimization of General Shell Structure • Compliant MEMS mechanism Design • Topology optimization of plate structure under stress, buckling, frequency and manufacturing constraints 	
<p>C</p>	<p>Area</p>	<p>Design of Launch Vehicle. AI, Machine learning (VSSC)</p>
<p>C1</p>	<p>Sub Area</p>	<p>Finite Element Code Development (VSSC)</p>
<p>C1.1</p>	<p>Software for the Generative design of Launch Vehicle Structures using AI</p> <p>Generative design is a method of using AI algorithms to generate and evaluate multiple design alternatives based on input from user. This design process can take many constraints into account including performance requirements, manufacturing process and materials to generate optimized designs. This proposal is to develop software for the Generative design of the launch vehicle structures.</p> <ul style="list-style-type: none"> • Topology optimization of Cylinder structure under stress, buckling, frequency and manufacturing constraints • Topology optimization of Cone Frustum structure under stress, buckling, frequency and manufacturing constraints 	
<p>D</p>	<p>Area</p>	<p>Materials and Manufacturing (VSSC)</p>
<p>D1</p>	<p>Sub Area</p>	<p>Metal Joining (VSSC)</p>
<p>D1.1</p>	<p>Development of technology for friction stir welding using bobbin tool for high thickness aluminium alloys (VSSC)</p> <p>Conventionally the friction stir welding of propellant tanks is performed using standard fixed pin tool. The fixed pin FSW needs rigid backing plate to support the work piece, which adds the complexity especially during cir-seam welding. Also, fixed pin requires high downward force since it is supported only from one side. The un-even heat distribution in fixed pin tool leads to increased residual stresses and high chances of root defects.</p>	

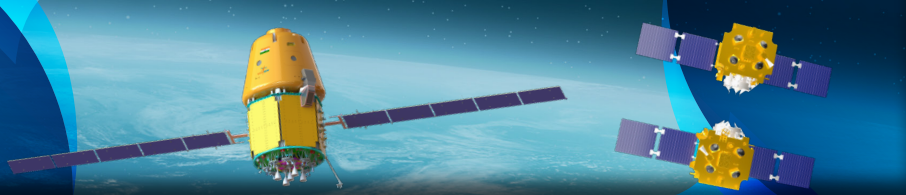

For the propellant tanks of thickness 12 to 14 mm, bobbin tool FSW technology is suitable due to the following advantages

- a) Elimination of backing plate
- b) Reduced welding downward forces
- c) More uniform heat distribution
- d) Reduced residual stress and distortion
- e) Better material flow and weld quality
- f) Welding at higher welding speed (low HI)

Work Envisaged:

- Design and development of bobbin tool technology for high thickness aluminum alloy (AA2219) weldments (12 mm and 14 mm).
- Optimization of bobbin tool (pin and shoulder), downward force and process parameters on the mechanical properties and defect formation in AA2219 weldments.
- Numerical modelling and experimental validation of bobbin tool FSW for high thickness weldments. Thermal (temperature profile, heat distribution) and mechanical aspects (residual stress and distortion) to be studied.
- Detailed mechanical properties (tensile properties at ambient and cryogenic temperatures-77K) and microstructural characterization of optimized BT-FSW AA2219 welds.

D2	Sub Area	AI/ML in Materials Engineering (VSSC)
D2.1		<p>Deep Learning based Microstructure and Mechanical Property Correlation in High-Strength Low-Alloy Steel (VSSC)</p> <p>This study aims to leverage deep learning techniques for the quantification of microstructural features, phase fractions, and prior austenite grain size (PAGS) in high-strength low-alloy steel(0.3C-CrVMo(ESR)/D6AC steel),establishing robust correlations with mechanical properties.</p> <p>The research focuses on integrating convolutional neural networks(CNNs) with metallurgical characterization techniques to automate thesegmentation and quantification of microstructural phases such aspearlite, ferrite, bainite, and martensite.</p> <p>High-resolution optical and scanning electron microscopy (SEM) - Electron-Back Scattered Diffraction (EBSD) images will serve as input for deep learning models trained to classify and quantify phases and grain structures.</p> <ul style="list-style-type: none"> • Date generation: Generation of different microstructure (martensite, lower bainite, upper bainite, pearlite and their mixtures) and corresponding mechanical properties in high strength low alloy steel through heat treatment (Experiments: 40-50 Nos).

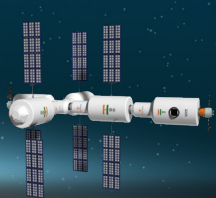

- Data Acquisition: Optical and SEM images of 0.3C-CrVMo(ESR)/D6ACsteel samples subjected to different heat treatments.
- Phase Quantification: Deep learning-based segmentation of ferrite, bainite, and martensite phases.
- Prior Austenite Grain Size Estimation: Reconstruction using deeplearning models trained on etched micrographs.
- Mechanical Properties Correlation: Linking microstructural parameters with tensile strength, hardness, and fracture toughness using machine learning regression models.
- Validation: Validation will be done using new set of parameters. (Variation - $\pm 5\%$).

E	Area	Propellants, Polymers and Chemicals (VSSC)
E1	Sub Area	Propellant (VSSC)
E1.1	<p>Development of a lab scale prilling process for producing spherical ammonium dinitramide (ADN) oxidizer (VSSC)</p> <p>Ammonium dinitramide (ADN) is a 'green' high energy oxidizer envisaged for use in solid and liquid propellants. The as-synthesised ADN is needle shaped with high aspect ratios which makes them not suitable for use in solid propellants. In order to use ADN for solid propellants, the as-synthesised ADN has to be converted into spherical particles by a suitable prilling methodology viz., emulsion crystallization, melt crystallization or spray crystallization so as to get ADN with two different average particle sizes viz., $60\pm 20\mu$ and $200\pm 50\mu$ with aspect ratios > 0.9. The spherical particles of ADN shall also be coated suitably with organic or polymeric material like 'stearic acid', 'cellulose derivatives', PMMA, PVA etc./inorganic material like 'aerosil' to prevent agglomeration and moisture ingress. The coating thickness shall be in the range of $2-5\mu$.</p> <p>Work Envisaged:</p> <ol style="list-style-type: none"> 1. To evolve a suitable lab-scale process for producing spherical particles of ADN from as-synthesised ADN. Sample quantities of ADN for spheroidisation studies shall be collected from VSSC/ ISRO. 2. Characterization of the produced spherical particles viz., particle size distribution, density and shape characteristics. 3. To identify suitable coating methodologies for the spherical ADN particles and undertake coating trials & characterization of the coated particles. 4. Subsequently, VSSC/ ISRO shall undertake the ignitability studies of coated ADN and compatibility with propellant ingredients viz., binder, plasticizer, metal fuel etc., to functionally characterize the spherical ADN particles. 5. Demonstration of both processes (spheroidization and coating of ADN) in a scale of 100-200g to VSSC. 	

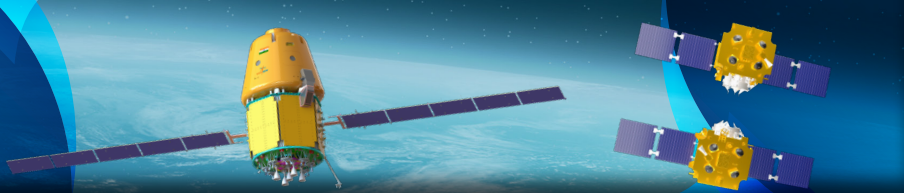

Theoretical modelling of cracking reaction of Endothermic fuel in the wall channel of scramjet combustor of an air breathing propulsion engine based on experimental studies (LPSC)

Air breathing/hypersonic propulsion is vital for advanced Space Transportation System for low cost access to space. As the air breathing engine propelled vehicle speeds increase (Mach no.>6), thermal problems multiply because of the effect of the increase in stagnation temperature of the inlet air. Although thermal effects can be mitigated to some extent by improved materials and passive cooling techniques.

However, sustained long duration hypersonic flight in atmosphere requires substantial heat sink. As an effective solution, the fuel with high heat sink capability itself can be used as a coolant for engine elements. Since preheating of the fuel is desirable before combustion, it can be circulated through heat transfer passages embedded inside the hot scramjet engine parts. Thus, the fuel removes the excess heat from the engine and in process; it is regenerative heated to the desired temperature. Traditional fuels use only sensible heat for cooling whereas endothermic fuels (C7-C16, aromatics, cyclic compound, catalyst, additives etc.) provide cooling through two routes, namely absorption of sensible heat from combustor wall and through the use of endothermic cracking reactions of fuel.

E1.2

The fuel can provide about 50% more heat sink capacity if it undergoes endothermic thermal cracking reactions at high temperature. As per design requirement the cracking chamber temperature and pressure is in the range of 800-900°C and 30-40 bar respectively. In order to understand the cracking behaviour of the fuel under the desired pressure and temperature it is necessary to model the cracking reaction inside the flow channel.

1. Experimental studies need to be conducted for capturing the intermediate for the cracking reaction for different grades of fuels. Intermediate may be captured through carrying out cracking reaction in conjunction with Laser/spectrometer. Further, based on the experimental data a details, a kinetic reaction rate mechanism shall be developed. The proposed chemical pathways/rate shall be developed as a Chemkin model that can be clubbed with CFD code for estimating the necessary cracking performance parameters.
2. This proposal also envisages the modelling and performance analysis of heat transfer and cracking reaction of the fuel though the channels of different dimensions (Length/Width/Diameter). Configuration of the channel will be provided by VSSC.
3. The modelling of the reaction shall cater the requirement of understanding of temperature / pressure profile of the channel, cracking profile (conversion vs length of the channel), product profile (concentration of products like C,C1,C2,C5,C6 etc. with length), chance of coke formation, heat extracted in the channel, & pressure profile analysis.

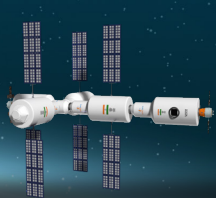

4. The study shall be extended for different fuels (JP-7, RP-1, JP-8) with varying composition. The effect of different kinds of additives (cracking initiators, coke inhibitor, cetane improvers, ignition delay improves, soot improvers etc.) on the chemical pathways also shall be studied.
5. Further, a comparative study needs to be conducted to find out the effect of MOC of channel tubes (SS316, TiO2 coating, Platinum coating, Alumina coating etc.). A theoretical kinetic shall be attempted to capture the interaction of wall with different kind of intermediates.
6. Finally, a consolidated study report shall be submitted. The report must contain the following,
 - Details of experiments and experimental set up for capturing cracking mechanism
 - A detail chemical pathways for cracking of different fuels JP-7, JP-8, RP-1 etc.
 - A spectrum of all the possible intermediates captured through optical sensors.
 - A reaction kinetics /chemkin file that can be interfaced with CFD model in COMSOL/ ANSYS FLUENT
 - Effect of % of additives on the cracking performance (P,T, coke, species, heat sink, phase fractions)
 - Effect of Geometry on the cracking performance and heat sink performance.
 - Effect of tube MOC on the coking and cracking parameters.

A detail CFD model in COMSOL/ANSYS/or .exe format that can predict the cooling channel performance for a combination of different fuels, additives, & combinations of tube MOC.

E2	Sub Area	Chemicals (VSSC)
E2.1		<p>Development of high temperature ceramic catalysts for monopropellants (VSSC)</p> <p>Conventional monopropellant based on hydrazine is catalytically decomposed using an active metal supported on a ceramic substrate. The use of new high performance monopropellants viz., ammonium dinitramide (ADN) and hydroxyl ammonium nitrate (HAN) requires a high temperature tolerant and structurally resistant catalyst. The combustion temperatures of these monopropellants are in the range of 1500-1700°C which requires a suitable high temperature ceramic catalyst with a suitable active metal. The proposed catalyst shall essentially consists of a high temperature ceramic support viz., alumina (heat treated at 1500°C), hexaaluminate, alumino silicate etc., with an active metal (20-30%) viz., Ir, Pt etc.,</p> <p>Work Envisaged:</p> <ol style="list-style-type: none"> 1. To identify and evolve a suitable ceramic support with a temperature capability of 1500-1700oC.

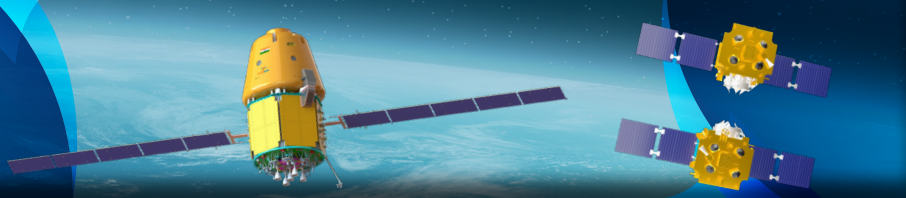

2. To undertake shape forming studies to produce granulates of different sizes viz., 1-2mm, 2-3mm etc.,
3. To carry out impregnation of the ceramic substrates with active metals (20-30%) and characterization of the catalyst.
4. Demonstrate the process in a lab-scale and supply of the catalyst (50-100g) to VSSC for evaluation in a thruster.

E3	Sub Area	Energetic Materials (VSSC)
-----------	-----------------	-----------------------------------

Development of Energetic Metal Organic Frameworks (EMOFs) (VSSC)

The development of high performance pyros require that energetic materials must contain high energy and be safe to handle and store. Therefore, significant research in the domain of energetic materials has been dedicated to the design and synthesis of high-energy and insensitive materials. However, with the improvement of the energy level of energetic materials, their safety is always compromised. To adjust the material structure and coordinate the contradiction between material energy and stability through an effective combination and reasonable arrangement of chemical bonds and structural motifs has become the research focus on energetic materials in the world.

E3.1 Energetic Metal–organic frameworks (EMOFs) have gained much attention because of their stable skeletons, controllable structural designs, and tuneable properties. Since EMOFs possess the merits of good heat stability and higher performance, have potential applications in the high energy field by the utilization of highly energetic ligands as coordination ligands.

It is proposed to take up synthesis of EMOFs having high thermal stability (>250°C) & high density (>2.0 g/cc). High nitrogen EMOFs can also be synthesized for gas generating applications.

Will be useful for high performance gas generators, high explosives for applications such as inflation and separation systems.

E4	Sub Area	Characterisation at cryogenic temperatures ≤ 20 K (VSSC)
-----------	-----------------	---

Cryogenic characterisation of foams and polymers (VSSC)

Liquid oxygen and liquid hydrogen is used as cryogenic propellants. Various polymers such as polyimides and foams are used for thermal insulation, thermal protection purposes in cryogenic tanks and associated systems. It is essential to study the behaviour and characterisation of such foams and polyimide films at low temperatures to the order of 20 K and below. It is also proposed to have a cryogenic characterisation facility for the evaluation of following properties:



		<table border="1"> <tr> <td>Materials to be tested</td> <td>Properties to be evaluated</td> </tr> <tr> <td>Rigid PU foam</td> <td>Thermal conductivity</td> </tr> <tr> <td>Polyimide film</td> <td>Tensile strength</td> </tr> <tr> <td>Cryo adhesive</td> <td>Compressive strength</td> </tr> <tr> <td>Flexible insulation materials</td> <td>Specific heat</td> </tr> <tr> <td>Premoulded foam pad</td> <td>Interface properties</td> </tr> <tr> <td></td> <td>CTE</td> </tr> <tr> <td></td> <td>Visco elastic properties</td> </tr> </table>	Materials to be tested	Properties to be evaluated	Rigid PU foam	Thermal conductivity	Polyimide film	Tensile strength	Cryo adhesive	Compressive strength	Flexible insulation materials	Specific heat	Premoulded foam pad	Interface properties		CTE		Visco elastic properties
Materials to be tested	Properties to be evaluated																	
Rigid PU foam	Thermal conductivity																	
Polyimide film	Tensile strength																	
Cryo adhesive	Compressive strength																	
Flexible insulation materials	Specific heat																	
Premoulded foam pad	Interface properties																	
	CTE																	
	Visco elastic properties																	
E5	Sub Area	Computational Modelling (VSSC)																
E5.1	<p>Computational Modelling of polyurethane foaming process (VSSC)</p> <ul style="list-style-type: none"> • Polyurethane foam process involves complex simultaneous reactions involving exothermicity. To understand the complexity and kinetics of the reactions computational modeling will be highly essential. This will also help to predict the product properties. • Computational model is to be developed to understand the foam expansion process for manufacturing applications and how in homogeneity affects the structural response of the product, including long term stability. • Study shall include the kinetics determination of the formulation taking into account the variation of isocyanate index, surfactant, catalyst & blowing agent. • Extent of reaction and viscosity variation during the course of reaction needs to be predicted for a stipulated kinetics and environmental conditions. • Computational modelling of foam expansion to design a mould filling process. • Physical, mechanical and thermal property prediction via the developed model. Effect of processing conditions on the cell size and final properties may also be studied. • Prediction of bubble size and bubble distribution may be attempted thus making it more predictive for foaming and aging. <p>Validation of prediction with respect to experimental values may be done.</p>																	
E6	Sub Area	Theoretical chemistry (VSSC)																
E6.1	<p>Theoretical analysis about Venus atmosphere’s corrosive effects towards designing structural materials for missions (VSSC)</p> <p>Design of materials for futuristic Venus missions is a challenge due to the peculiar nature of the atmosphere. At the Venus surface, the atmosphere consists mostly of CO₂ and N₂, as well as trace amounts of SO₂; H₂O, CO, OCS, HCl, HF, and H₂S with a temperature of 467°C and a pressure of 9.2 MPa. Even though a plethora of literature is</p>																	

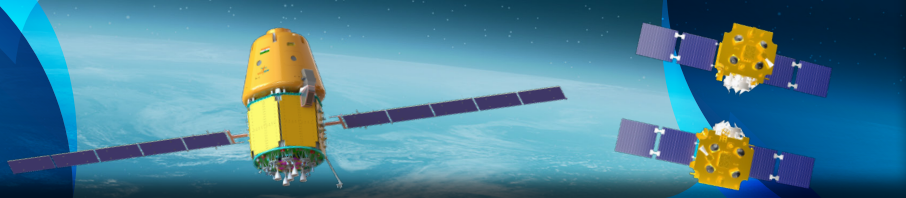

	<p>available regarding the Venus atmosphere and its chemistry. There exist limited reports regarding the correlation of Venus atmosphere chemistry with corrosion of materials. A theoretical understanding of the molecular cluster formation, photolytic degradation of different molecular species in the Venus atmosphere and their interaction with different structural materials will enable us to understand the material reactions arising from the trace quantities of corrosive constituents in the Venus atmosphere. This study will give more insight while designing/processing of structural and electronics materials that need to operate for months unprotected from the Venus surface environment.</p>	
E7	Sub Area	High performance Polymers (VSSC)
E7.1	<p>Development of Polybenzimidazole (PBI) fibers (VSSC)</p> <p>Polybenzimidazole is a high performance synthetic polymer (capable to form strong fibers) with exceptional thermal (>500°C) and chemical stabilities and does not exhibit a melting point. It is prepared by the condensation polymerization of tetramines with dicarboxylic acids at high temperatures. It has limited solubility in solvents, which restricts the fiber spinning process. The country does not have the technology of PBI fibers.</p> <p>The plan involves</p> <ul style="list-style-type: none"> • Supply of PBI polymer in resinous form (Polyphosphoric acid as solvent)/in solid form by VSSC (100-200 g level) • Identification of suitable solvent for dissolving PBI to facilitate spinning. <p>Preparation of PBI fibers using solution or melt spinning technology by party.</p>	
E8	Sub Area	Nonisocyanate polyurethane coating (Antimicrobial coating) (VSSC)
E8.1	<p>Nonisocyanate polyurethane based biocompatible antimicrobial coating (VSSC)</p> <p>Antimicrobial coating for space mission is highly anticipated. Here the proposal is focussing on the development of antimicrobial coatings based on nonisocyanate polyurethane. The coating should be biocompatible and should not contain any VOC (solvent free).</p> <p>The objective of this proposal is to</p> <ol style="list-style-type: none"> 1. Synthesis of Hybrid polyhydroxyurethanes/ Hybrid non-isocyanate polyurethanes (HPHU/HNIPU) from synthetic (PDMS based) as well as by using bio-based molecules such as vegetable oils, fatty acids, terpenes etc., via. the synthesis of cyclic carbonate by the incorporation of CO₂ into an epoxy. 2. The synthesis of HPHU by the addition of bio compatible epoxy into cyclic carbonate followed by reaction with bio based polyamines. 3. The HPHU synthesised by the above mentioned routes will be evaluated for physical, thermal, mechanical and morphological properties. <p>The coating realized should be evaluated for microbiological analysis and biocompatibility and cytotoxic studies.</p>	

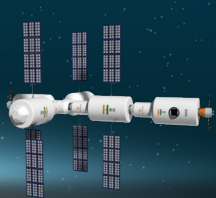

E9	Sub Area	Sprayable TPS Application Technology (VSSC)
E9.1		<p>Development of a reinforced matrix coating system capable of mixing liquid resin & reinforced material externally to apparatus prior to impact on substrate (VSSC)</p> <p>Coating substrates with reinforced resin matrices, such as liquid resins reinforced with fibers, glass micro spheres, or other reinforcing materials, conventionally requires mixing the liquid resin with the reinforcing material and then spraying the mixture on to the substrate. However this is limited due to the low sprayability of the liquid resins which are typically highly viscous, the limit in attainable coating thickness, and the high amount of waste material generated.</p> <p>Pumping of high viscose liquid resin through the lines and nozzle of a spray coating apparatus is difficult and requires large amounts of energy. In order to reduce energy requirements and to simplify the spray coating process, the viscosity of the liquid resin is often reduced by mixing the liquid resin with a solvent. Typically, however, solvents useful in spray coating processes are generally environmentally hazardous.</p> <p>Conventional spray coating processes comprise combining a liquid resin, solvents, reinforcing material, and other conventional constituents such as curing agents, biocides, etc., in a vat to form a mixture. This mixture is then pumped from the vat through lines to a nozzle where it is atomized and sprayed onto the substrate. Once the mixture has been applied to the substrate, the solvent is removed there from by the natural evolution of volatile gas and/or by applying heat to the mixture to fasten the solvent evolution.</p> <p>The proposal is to design and model an application system where in a high viscous liquid resinis atomized and dispensed towards the substrate through a standard liquid nozzle located at the axis of the apparatus and a stream of fluidised (in air) solid filler particle (viz. Cork powder, glass micro-balloon) is introduced peripherally around the resin jet. The mixing of reinforcing solid and resin occurs at the exterior of the applicator due to the local pressure difference prior to the impact on the substrate.</p> <p>Objectives of the respond project are,</p> <ol style="list-style-type: none"> 1. Design of a suitable applicator system. 2. Modeling & simulation of the system and optimization of design. <p>Fabrication of prototype model, demonstration of performance and validation of design.</p>
E10	Sub Area	Polymers (VSSC)
E10.1		<p>Development of Nanofiltration & Reverse Osmosis Membranes for Water Recovery Systems of Space Habitat (VSSC)</p> <p>Membrane-based water purification system are state of art and highly effect method for water recovery and reuse from various sources such as</p>

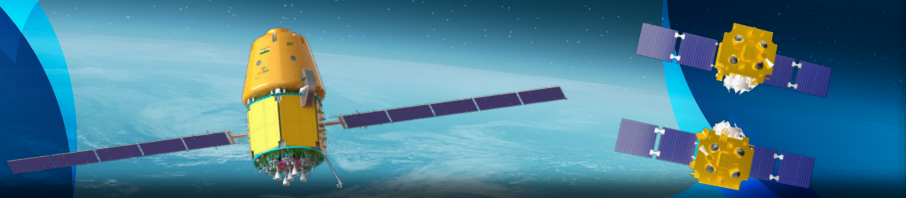

- Urine (primary source of wastewater).
- Grey water (from hygiene, cleaning & shower).

A combination of reverse osmosis (RO) and filtration technologies along with distillation & chemical treatment to purify water is used. However a more energy efficient and high water recovery systems are possible only with cascade of specially designed RO and nano filtration membranes. Nanofiller based membrane filtration systems are often preferred over the existing systems to overcome the issues like energy, size and durability and also to remove heavy metals, organic pollutants and bacteria.

Advantages:

Use of nano materials (CNTs, graphene, Silver nano particle etc.) embedded polymeric membranes are the most promising options for high-performance, energy-efficient water purification in space due to their ultra-high permeability, tuneable pore size, antibacterial properties and anti-fouling properties.

Scope of the work:

To develop a working prototype of an efficient membrane based filtration system using Nano filtration+ Reverse osmosis membrane (Polyamide thin film composite (TFC) with integrated aquaporin proteins with polysulfone as support material for purifying soap/shower water with the following features:

- Capacity of water filtration 30 lit/day
- Water recovery >98%
- Permeate flux high & nearly constant at all times
- Low energy consumption
- Fouling can be reduced or eliminated by physical cleaning (Avoid chemical cleaning)
- Overall weight/mass should be less

F	Area	Energy System (VSSC)
F1	Sub Area	High energy density battery system (VSSC)
F1.1	<p>Development of Si nanowires infused Graphite anode materials for Ultra high energy density battery systems (VSSC)</p> <ul style="list-style-type: none"> • Silicon remains a promising material for Li ion battery anodes since it provides the highest known specific capacity (4200 mAh/g Vs. Graphite 372 mAh/g, 10 times). Presently Si nano material's as a composite form are commonly used for high energy Li ion batteries designs with limited silicon content 5-20 % and the utilization are limited to >1000 mAh/g for containing the volume expansion and the associated capacity degradations. • Scope of further energy density improvement to realize ultra high energy density class battery systems (> 400 Wh/kg) relies on the successful development of 3D nano 	

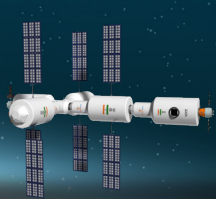

	<p>architecture like Si nanowires embedded graphite composites combining high Li storage and cycle life characteristics suitable for real world applications.</p> <p>Advantages: As a direction oriented Si nanowires, it is able to swell without breaking and have the advantages of high surface to volume ratio and enable better Si capacity utilisation in the composite matrix. Si nanowires infused in Graphite able to withstand more volume change without undergoing pulverisation unlike particles and limited cracking thereby extended the cycle life. This kind of nano structures exhibits add-on advantage of shorter diffusion path for Li ionic species, thus offering the possibility of fast charging and higher discharging rates compared to 2D Nano composites.</p>	
G	Area	Formal Verification (VSSC)
G1	Sub Area	Language Compiler for Microprocessor, Formal Verification (VSSC)
G1.1	<p>Formal Verification of Vikram3201 Ada Cross-Compiler (VSSC)</p> <p>The research proposal aims at formal verification of in-house developed Ada cross-compiler for Vikram3201, a 32-bit processor with indigenous instruction set architecture. Ada cross-compiler has been developed in-house and used for development of flight software for Vikram3201-based embedded systems. The research is aimed at formally proving that the compiler is error free.</p>	
H	Area	Model-based Software Development Framework (VSSC)
H1	Sub Area	Software development framework using Model-based techniques to provide a Low-Code/No-Code platform for future NGC flight software development (VSSC)
H1.1	<p>Low-Code Software Development Platform for OBCs (VSSC)</p> <ul style="list-style-type: none"> • Software development process in general is transitioning from a traditional manual programming model to Low-Code/No-Code based software development process • Visual Programming, Model based Development, Formal Specification etc. all are different approaches to this general goal • This proposal envisions such a platform to auto generate software from GUIs, configuration files, specifications etc. instead of manual software coding • The platform shall support customization for in house safe subset of high level languages and Instruction Set Architecture of indigenous processor for generating Assembly functions 	
H2	Sub Area	Launch vehicle sequential system (VSSC)
H2.1	<p>High power Laser diode device design, development and realization (VSSC)</p> <p>Design and realization of high power laser diode with 975nm wavelength. Power level shall be adjustable with input current to the laser diode. Power output shall be programmable from 3watt to 10watt by adjusting input current to laser diode.</p>	

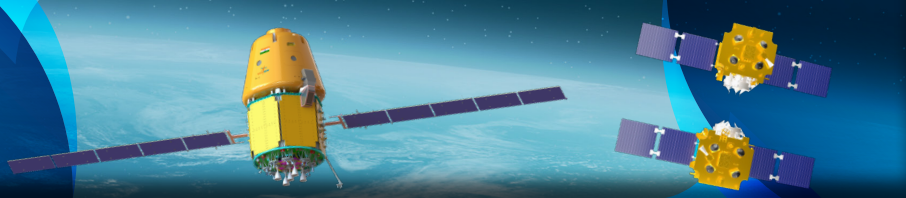

I	Area	Sensing Systems (VSSC)
I1	Sub Area	Instrumentation, Data Acquisition and Telemetry VSSC
I1.1	<p>Graphene-based Sensors and Sensing Systems (VSSC)</p> <p>Graphene is a two-dimensional material that exhibits superior electrical and mechanical properties when compared to Silicon for sensing and electronic device realization. Realization of sensors based on Graphene platform is expected to lead to high performance, low-power, miniaturized sensing systems suitable for aerospace application. Increased sensitivity, improved operational ranges and better accuracy are expected performance gains from these sensors. Sensors and sensing systems for parameters such as pressure, strain, vibration, acoustics, humidity, gas detection and biomedical health monitoring and Hall effect sensors are suitable candidates for development. This involves development of sensor, signal conditioning / interrogation electronics, packaging, calibration and compensation as required.</p>	
J	Area	Radio Sounding system development for Planetary Ionospheric studies (VSSC)
J1	Sub Area	Scientific probes, Sensing Antennae & RF Systems (VSSC)
J1.1	<p>Wideband transmitting and receiving antenna for RF; Efficient RF transmitting and receiving systems with onboard RF data processing (VSSC)</p> <p>The atmosphere of planetary bodies like Moon is characterized by the absence of a unified magnetic field. This allows the direct interaction of solar wind with planetary surface and atmosphere, which in turn leads to the formation of an ‘ionosphere’. Such an ionosphere would be an ideal plasma laboratory to understand the behaviour of plasma in the absence of a unified magnetic field. The plasma distribution, both spatial and temporal, would depend on the magnetic field conditions unique to the heavenly body. A typical requirement for such a measurement in the case of a lunar mission is as follows: the transmitter sweeps in the frequency range of 90KHz to 1MHz. The sounding is proposed to be done in about 200 discrete steps. The pulse width is variable in the range of 5-40µs, with preferably a pulse repetition frequency of 500Hz. The envisaged peak pulse power is 5W.</p> <p>The project envisages development of an RF transceiver system with front-end antenna suitable for this. The system will thus aid the investigation of the temporal variations of magnetic field in the lunar or planetary ionosphere in the vicinity of its surface under varying solar conditions.</p>	
K	Area	Superconductor based Electromagnetic Cage (VSSC)
K1	Sub Area	Superconductor, high current electronics, cryogenics (VSSC)
K1.1	<p>Development of a superconductor based electromagnetic cage for active radiation shielding in outer space (VSSC)</p>	

	<p>The proposal aims to develop and prototype a high temperature superconductor based electromagnetic cage which can offer active radiation shielding in outer space. This will offer protection against the harmful effects of radiation and thereby enable long term survivability of human in outer space.</p>	
L	Area	Avionics-Communication Systems (VSSC)
L1	Sub Area	Development of a Fully deterministic variant of the Ethernet protocol for communication in a multi computer architecture with capability of data rates beyond 100Mbps (VSSC)
L1.1	<p>Fully deterministic variant of the Ethernet protocol for interprocessor communication in a multi computer architecture with capability of data rates beyond 100Mbps (VSSC)</p> <p>The proposal aims to develop a fully deterministic variant of the Ethernet protocol which will enable the development of avionics architecture with multiple computers interconnected by this high speed serial link. The developed protocol should be capable of communicating beyond 100Mbps.</p>	
M	Area	Superconductor based electromagnetic field generator for gravity generation (VSSC)
M1	Sub Area	Superconductor, high current electronics, cryogenics (VSSC)
M1.1	<p>The proposal aims to develop and prototype a high temperature superconductor based electromagnetic field generator which can generate a rotating field to spin human habitat modules for generating gravity.</p>	
N	Area	Aerospace Engineering (VSSC)
N1	Sub Area	Development of Tools (VSSC)
N1.1	<p>Tool Development (VSSC)</p> <p>With the advent of higher computing power, fidelity of numerical simulations is also increasing. Second order RANS simulations are routinely carried out for aerodynamic design and characterization. Improved fidelity can be achieved by carrying out Large Eddy Simulations with higher order of accuracy. Towards this, a higher order solver is essential which can be based on Discontinuous-Galerkin (DG) or the Flux-Reconstruction (FR) framework which has shown promise in the recent past. As the configurations on which the solver will be used are not amenable for structured grid, the solver has to be based on 3D unstructured grid topology with mixed elements such as tetrahedrons, hexahedrons, triangular prisms and pyramids. Additionally, most of the flows over launch vehicles and re-entry bodies are high Mach number flows. Hence the solver should be designed for compressible flows with shocks.</p>	

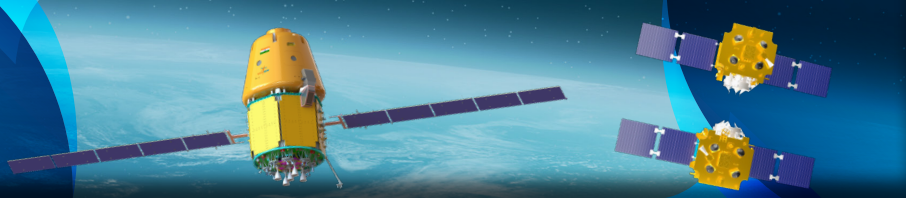

<p>N1.2</p>	<p>Software for three dimensional polyhedral mesh generation on arbitrary geometries (VSSC)</p> <p>Grid generation is an integral part of a CFD simulation process. Conventionally, mixed element grids involving tetrahedrons, hexahedrons, pyramids and triangular prisms have been used in an unstructured solver. But in recent past, polyhedral grids have shown promising results in terms of accuracy and robustness. Hence an automatic polyhedral grid generator which can generate a grid on an arbitrary geometry is sought.</p>	
<p>N1.3</p>	<p>Development of empirical tool or simplified mathematical tools for preliminary aerodynamic data generation for wingbody configuration for ground proximity conditions (VSSC)</p> <p>Detailed moving mesh based CFD simulations are computationally expensive and time consuming and this makes it non-feasible for detailed preliminary investigations during design phase. Empirical tools or simplified mathematical tools are promising candidates to generate aerodynamic data for winged body configurations during design phase with quick turn around time. Once the configuration is finalized, designers can make use of computationally expensive moving mesh based CFD solvers. Currently we have high fidelity robust CFD solvers to handle the second part for accurate data generation. Proposals are invited to develop empirical/mathematical tools capable of generating aerodynamic data for winged body configurations, accounting for dynamic ground proximity, with reasonable and acceptable levels of accuracy.</p> <p>Typical parameters expected from the tool includes sink rate, aspect ratio, height above ground, and other essential design parameters. Results should be validated for minimum two cases, supplied by VSSC or published in literature.</p> <p>Source code and executable files should be installed in VSSC computational facility and proper training to be given to our Engineers.</p>	
<p>N2</p>	<p>Sub Area</p>	<p>Additive Manufacturing, 3D Printing (VSSC)</p>
<p>N2.1</p>	<p>Design and realisation of 3D printable sandwich deck plates with provision for internal cooling (VSSC)</p> <p>Presently, aluminium sandwich deck with honeycomb core support avionics packages in launch vehicle and satellites. These deck plates are process, schedule and cost intensive. In addition to this, thermal dissipation systems are provided in and around the deck for dissipating the heat generated by avionics packages.</p> <p>The proposal is to design a 3D printable sandwich deck with aluminium skin and lattice type core along with internal cooling veins system which is capable of supporting the structural and thermal environment.</p> <p>The proposed system shall be printed in a single go with internal cooling veins ensuring minimal post processing options.</p>	

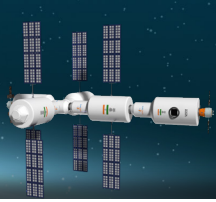

N3	Sub Area	Composite Lattice structure (VSSC)
N3.1		<p>Development of theoretical models of composite lattice cylinders and cone type structures (VSSC)</p> <p>Composite filament wound lattice structures are evolving optimized construction for aerospace applications. Comprehensive theoretical model for lattice design are limited. The proposed topic is the development of a comprehensive theoretical model capable of predicting the structural behaviour (deflection and strains), possible local and global failure modes of cylindrical and conical structures under compression, tension and bending loads.</p> <p>The theoretical model shall be validated using FE and proto hardware testing.</p>
O	Area	Aerodynamics (VSSC)
O1	Sub Area	Experimental aerodynamics (VSSC)
O1.1		<p>Development of Background Oriented Schlieren system for use in Trisonic wind tunnels (VSSC)</p> <p>The proposal envisages development of a background oriented schlieren setup for a viewing area of 500mm diameter in a trisonic wind tunnel.</p> <p>Design and procurement of required optics (if necessary) Development of algorithm for measuring density preferably in Matlab.</p> <p>Validation with standard 2D wedge and 3D cone models Demonstration of the BOS in ISRO Tri-sonic Wind Tunnel on a Crew Module.</p> <p>(VSSC TWT possess necessary windows, light source and collimated beam).</p>
O2	Sub Area	CFD, Unsteady Simulations, Large separated flows (VSSC)
O2.1		<p>Computational investigation of dynamic stability derivatives for semi-ballistic re-entry modules (VSSC)</p> <p>Semi-ballistic re-entry modules are used for ferrying crew to and from space. The module spends significant time in atmospheric phase while nominal reentry. During abort missions, the module may experience re-orientation from an angle much away from desirable trim angle, hence undergoing large pitching motion. These modules are reported to be dynamically unstable at subsonic and transonic speeds in literature. Accurate computation of these phenomena is essential for precise simulations of its behaviour prior to parachute deployment. Unsteady CFD simulations capturing the time lag effects in large separated flows pave the way to study the underlying reasons and possible solutions for undamping behavior. Apart from high fidelity simulations, data processing and usage also plays a significant role.</p>

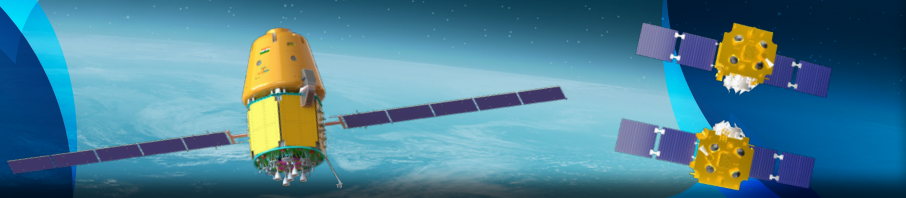

O3	Sub Area	Experimental aerodynamics (VSSC)
O3.1		<p>Development of forced rotation roll damping rig for use in Trisonic wind tunnels</p> <p>The proposal envisages development of a forced rotation roll damping rig for roll damping coefficient estimation in trisonic wind tunnels.</p> <p>Roll speed: 35 RPM to 2000 RPM</p> <p>The proposal consists of measuring the RM of rotating model using a balance / torque cell, rotating the model at various constant speeds, speed measurement, a feedback circuit for maintain the speed and suitable control system. The scope of work includes design and finalization of required motors, slip rings, hall effect sensors, angle measurement system, software for control, simulation results etc and purchase order specifications for each items.</p>
O3.2		<p>Methods to specify the size and shape of Boundary Layer trips on wind tunnel models at low and high Angle of Attack in subsonic regime (VSSC)</p> <p>During lift off of launch vehicles, the vehicle AOA continuously decreases from 90° to 0°. Typically scaled wind tunnel models are used in WT for obtaining loads at various aoa. At higher AOA, in order to get the loads accurately, the flow field on both the WT model and in flight should be same. Hence, various kinds of BL trips are used on WT models to simulate the flight Reynolds number. This proposal seeks an appropriate procedure for arriving at the size and shape of boundary trips on a variety of wind tunnel models in the angle of attack range of 0° to 90°.</p> <p>Experimental investigation to derive the procedure/methodology/pattern to distribute the boundary layer trips on typical scaled down models of slender body (SSLV/ Gaganyaan/TVP etc), blunt body (Crew Module) and lifting body (RLV, GEV) at subsonic speeds and demonstrate aerocoefficient independence with speed by proper BL tripping in speeds upto 80 m/s at various angles of attack and wind plane angles. Alternatively tunnel flow turbulence can be increased by use of appropriate grids and TBL on model can be demonstrated.</p>
O3.3		<p>The development and integration of Delayed Detached Eddy Simulation (DDES) and Wall model Large Eddy Simulation (WMLES) for in-house solver PRAVAHA (VSSC)</p> <ol style="list-style-type: none"> 1. To develop DDES and WMLES and integrate them into the existing in-house solver "Parallel RANS Solver for Aerospace Vehicle Aerothermodynamic Analysis (PRAVAHA)" which is cell centered finite volume solver on unstructured grid (C++ language to be used). 2. Implement Kinetic Energy and Entropy Preserving schemes on polyhedral mesh elements along with adaptive schemes in the vicinity of shock.

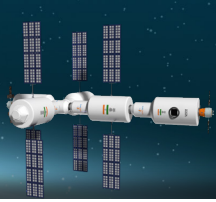

	<p>3. Implement various wall models for WMLES.</p> <p>4. The validation of the solver w.r.to boundary layer flows (with and without separation) and shock-boundary layer interaction with existing literature for realistic engineering geometries (external flow over launch vehicle& supersonic jet flows).</p> <p>Demonstration of these solver in predicting the noise levels for supersonic jets and external flow over launch vehicles.</p>	
O3.4	<p>Experimental Fluid Structure Interaction study to understand parachute dynamics (VSSC)</p> <p>Parachute system is an essential system for recovery missions. We need to generate sufficient experimental data and the same is not available to the required level. Proposals are invited to carry out the parametric studies using a series of experiments. Experimental database for parachutes with various parameters like wiser length, flyout angle, flyout length, material flexibility, multiple parachutes and fore-body effect needs to be generated. We are looking for proposals from academia and/or industries, having necessary facilities or capable of establishing the necessary facilities for performing fundamental experiments to understand parachute dynamics, (both single and cluster).</p>	
P	Area	Propulsion (VSSC)
P1	Sub Area	Hybrid Motor (VSSC)
P1.1	<p>Modelling of fuel regression and pressure behaviour in Hybrid Motor (LPSC)</p> <p>Burn rate of solid fuel in Hybrid Motors depend on convective heat transfer to the fuel grain, fuel pyrolysis and oxidiser flow rate and its evaporation. For obtaining the pressure-time behaviour and oscillations in a hybrid motor, the coupling of the LOX evaporation and the heat transfer based fuel regression needs to be modelled. The temperature variation in the fuel grain and the recession of the fuel grain due to regression also need to be modelled. A conjugate heat-transfer based model to predict the pyrolysis rate of HTPB fuel based on heat-flux at the fuel surface and the moving mesh to account for the recession of the fuel grain due to burning needs to be developed and implemented, along with a suitable combustion model in a CFD package to enable full transient pressure behaviour of the hybrid motor.</p>	
Q	Area	Aerothermal (VSSC)
Q1	Sub Area	Radiant heating (VSSC)
Q1.1	<p>Design and Development of a Graphite strip heater to operate at temperature above 3000degC in ambient sea-level condition (LPSC)</p> <p>Graphite radiant heaters can achieve very high heat flux for long duration. And the shape of heater can be appropriately made to suit the specimen. The current technology of quartz sealed tungsten filament-based lamps to simulate high heat flux have a limitation owing to the oxidation of tungsten and melting of quartz.</p>	

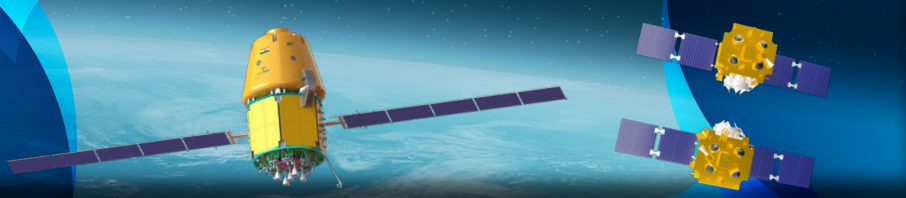

1. Development of tantalum carbide or similar high temperature coating to prevent oxidation of Graphite at high temperature
2. Selection of fine grain Graphite grade compatible for the coating and operation at temperature >3000degC
3. Develop procedure such as plasma spray for coating application on Graphite strip heater element.
4. Develop a small scale test setup with stepdown transformer, rectifier and filters for heating the graphite heater to temperatures above 3000degC.

Demonstrate the survivability of coating for repeated use at temperature >3000degC for sustained heating for 30 minutes.

Q2	Sub Area	Non-linear Control (VSSC)
-----------	-----------------	----------------------------------

Design techniques for the transient behavior of systems with Lyapunov based control design in spacecrafts and satellite launch vehicles (VSSC)

Lyapunov based control design always ensure the stability of the non-linear systems. However, till date this technique lacks a standard methodology for the design of the transient behaviour unlike in linear systems, where they are approximated as 2nd order systems for performance analysis. Transient performance is critical for systems like launch vehicles and spacecrafts as there are numerous uncertain sources of disturbances possible to impact while in flight. Development of this technique will boost the scope of implementation of Lyapunov based control algorithms for future applications which ensures stability along with the expected transient phase response.

R	Area	Photonic Thruster (LEOS)
----------	-------------	---------------------------------

Development of CNT (carbon nanotube) ablating film for laser based propulsion systems (LEOS)

CNT-based ablating films will have better specific impulse and low dead mass compared to other materials which are being used in ablating film fabrication. The current proposed research is towards the realization of the CNT-based ablating film for micro-newton thruster applications employing the carbon nanotube-based films developed based on the spray coating method. Ablation films are required for the thrusters with a thrust of the order of micro-Newton. The parameters, namely specific impulse and momentum coupling coefficient of ablating films, play a major role in deciding the performance of the thruster. Thrust level of micro-Newton thruster: approx. 100 μN; specific impulse >: 650 s; laser power: 15 W pulse laser source (~0.1 to 10 ms pulse at 10-20 Hz repetition rate). The main objectives of interest are a) development of CNT-based ablating film for micro-Newton thruster applications; b) characterization of properties, namely adhesion, durability of ablating film on the substrate, and laser ablating properties; and c) fabrication of 1-meter-long ablating film.

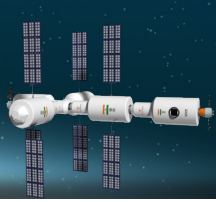

S	Area	Range Operations (SDSC SHAR)
S1	Sub Area	Meteorology (SDSC SHAR)
S1.1		<p>Enhancing Space Launch Vehicle Safety through X-Band Doppler Weather Radar Assimilation in NWP Models (SDSC SHAR)</p> <p>Space launch operations are highly sensitive to weather conditions, particularly during the critical launch window. Severe weather events such as heavy rainfall and thunderstorms can pose significant risks, necessitating accurate and timely weather predictions. This research proposes the integration of high-resolution X-band Doppler Weather Radar data into Numerical Weather Prediction (NWP) models using advanced data assimilation techniques. The objective is to enhance the accuracy of Nowcasting and short-term forecasts, thereby optimizing weather assessments and ensuring the safety of space launch operations.</p>
S1.2		<p>Hybrid Data Assimilation Techniques for Upper Winds, Monsoon Rainfall, Rapid Cyclone and Thunderstorm, and Lightning Prediction in Launch Environments (SDSC SHAR)</p> <p>Hybrid data assimilation methods that merge traditional meteorological data—such as Automatic Weather Stations (AWS), wind profilers, lightning observations, and ceilometers—with high-frequency inputs from X-band radars and satellite imagery. The integrated approach aims to accurately capture the fast-evolving dynamics of severe weather systems, including upper winds, monsoon rainfall, cyclones, thunderstorms, and lightning activity. Such advancements are critical for enhancing the reliability of weather predictions, ultimately providing essential decision-making support for safe and efficient space launch operations.</p>
S1.3		<p>AI-Driven Upper Wind Forecasting for Enhanced Space Launch Safety: Integrating High-Resolution Wind Profiler and GPS Radio Sonde Observations (SDSC SHAR)</p> <p>Research proposal focuses on developing a scientifically rigorous, AI-driven framework for short-range prediction of upper atmospheric wind conditions critical to space launch operations. By integrating high-resolution wind profiler measurements with GPS radio sonde vertical profiles, the project aims to design and implement advanced data assimilation techniques and machine learning models. These models will capture the dynamic atmospheric variability over short time horizons, thereby providing high-fidelity forecasts essential for optimizing launch trajectories and mitigating aerodynamic risks. The approach promises to enhance operational decision-making and overall mission safety by delivering timely and accurate wind predictions in the complex upper atmospheric environment.</p>

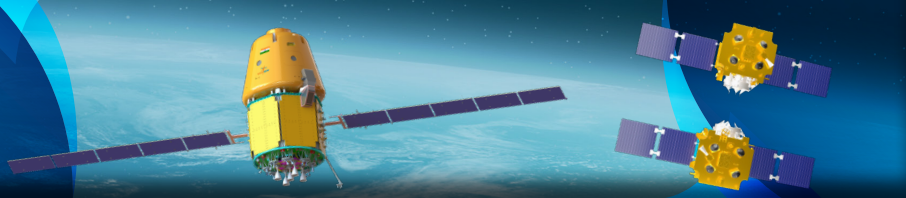

<p>S1.4</p>	<p>B. AI-Enhanced High-Resolution Short-Range Forecasting of Near-Surface Winds for Space Launch Operations (SDSC SHAR)</p> <p>Research proposal aims to develop state-of-the-art AI/ML models for the high-resolution, short-range prediction of near-surface winds (up to 100m) tailored for space launch operations and lift-off wind monitoring. By integrating diverse datasets—including long-term climatological observations, reanalysis data, and forecast outputs from ECMWF and WRF NWP models—the project seeks to capture fine-scale wind variability essential for launch safety. Advanced data assimilation and machine learning techniques will be employed to fuse these heterogeneous sources, resulting in improved real-time forecasts that support critical decision-making during launch operations and Liftoff.</p>
<p>S1.5</p>	<p>Rainfall prediction and type classification over the East-coast of India (SDSC SHAR)</p> <p>This research aims to predict rainfall patterns and classify the types of rainfall over the east coast of India using multiple meteorological instruments i.e., Micro Rain Radar (MRR), Ceilometer, Liquid Precipitation Monitor and Satellite observations. The Liquid Precipitation Monitor will provide measurements on real-time liquid precipitation, Ceilometer will inform about Cloud height and MRR offers vertical profiles of rain rate, liquid water content and drop size distribution at 22.24 GHz. A possible outcome of the study is an integrated model to predict rainfall intensity and type (e.g., Convective, Stratiform, Intermittent etc.) with high accuracy. This will enhance weather forecasting capabilities for localized rainfall prediction.</p>
<p>S1.6</p>	<p>Weather forecast at local region using foundational weather models (SDSC SHAR)</p> <p>Recent advancements in foundational weather models, such as Microsoft’s ClimaX, Huawei’s Pangu-Weather, and Google’s GraphCast, have demonstrated superior predictive capabilities compared to traditional Numerical Weather Prediction (NWP) models like GFS and WRF. These deep learning-based models leverage global reanalysis datasets and have shown remarkable skill in medium-range forecasting.</p> <p>In this context, an open-source weather and climate foundational model, pre-trained on ERA-5 reanalysis data, can be fine-tuned using high-resolution local meteorological observations from the ASRF observations. By integrating multi-source observational datasets, including ground-based sensors, remote sensing products, and reanalysis data, the model can be adapted to enhance regional forecasting accuracy. Furthermore, embedding spatiotemporal meteorological features into the model will allow for improved downscaling and high-resolution forecasts tailored to specific local conditions. This approach aims to bridge the gap between global-scale predictions and localized atmospheric dynamics, enabling more precise short- to medium-term weather forecasting.</p>

S1.7	<p>Water isotope analysis over the East-coast of Indian region during Cyclonic events (SDSC SHAR)</p> <p>This research aims to analyse the water isotope composition over the Chandipur region of eastern India during cyclonic events to better understand the impact of extreme weather on the local hydrological process. By studying the stable isotopes of water, the research can investigate cyclonic rainfall, evaporation and water vapour transport affect the isotopic signatures. Data will be collected periodically before, during and after a cyclonic event to trace the movement and transformation of water at the eastern part of India. This research can contribute to improved understanding of cyclone-induced hydrological behaviour.</p>
S1.8	<p>Aromatic VOCs at Major Road junctions in Metropolitan cities in India (SDSC SHAR)</p> <p>The scope of the research aims to analyze the concentration and sources of aromatic volatile organic compounds at major road junctions in metropolitan cities of India. The Thermal-Desorption Gas Chromatograph Flame Ionisation Detector (TD-GC-FID) and Volatile Organic Compound (VOC) analyzer can measure the levels of key aromatic VOCs which are primarily emitted from vehicle exhaust, industrial activities and traffic congestion. This study can assess the temporal and spatial variation in VOC concentrations and contribute to understanding and the impact of vehicular emissions on air quality and public health in urban settlements.</p>
S1.9	<p>Ionospheric observation using Ionosonde (SDSC SHAR)</p> <p>This research aims to enhance understanding of atmospheric dynamics. Ionosondes, which measure the electron density and later structure of the ionosphere can provide valuable data on ionospheric anomalies, radio signal propagation and space weather events. This study is expected to contribute to improved space weather forecasting, calibrate communication & navigation system at regions influenced by coastal geography.</p>
S1.10	<p>Investigation of interaction among aerosol, cloud and rainfall over the East coast of India during Indian Summer Monsoon (SDSC SHAR)</p> <p>This research aims to investigate how atmospheric aerosols which are tiny particles suspended in the air, influence cloud formation and impact the amount of rainfall by influencing cloud microphysical properties. The key points in this research it to better understand the impact of aerosols and their effects as parametrization in Numerical Models or in AI-based Foundation Models. In this context, data from Robotic Sun Photometer, Aethalometer, Nephelometer, Ceilometer, Cloud Radar etc. can be used along with satellite imagery data for evaluating the role of aerosol-cloud-rainfall association.</p>

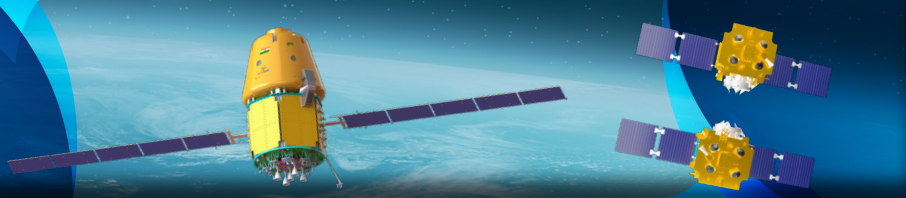

<p>S1.11</p>	<p>Middle & upper atmospheric study using VHF atmospheric Radar (SDSC SHAR)</p> <p>This study of the middle and upper atmosphere aims to advance the understanding of atmospheric dynamics and ionospheric interactions. In this work, phenomena such as atmospheric waves, turbulence ionospheric irregularities which affect communication systems & satellite operations are to be studied. Detailed analysis of turbulence and wind dynamics helps to better understand atmospheric circulation patterns and their impact on global weather systems.</p>	
<p>T</p>	<p>Area</p>	<p>Solid Motor Performance & Environmental Test Facility (SDSC SHAR)</p>
<p>T1.1</p>	<p>Developing a jet noise source localisation technique using a microphone array with appropriate beam forming algorithms (SDSC SHAR)</p> <p>Locating the jet noise sources in the lift-off scenario of a launch vehicle will benefit highly in the suppression of the noise sources. Present method proposes to use an array of microphones and employ suitable algorithm and develop a code to locate the noise sources.</p>	
<p>T1.2</p>	<p>Modelling and evaluation of damping in threaded joints of load cells and its impact on measuring dynamic force components (SDSC SHAR)</p> <p>During static test, the thrust load transfer is through threaded joints. The thread damping is important with respect to the dynamic thrust measurement. The objective is to model and experimentally evaluate the threaded joint damping for unsteady load transfer.</p>	
<p>U</p>	<p>Area</p>	<p>Vehicle Assembly and Launch Facilities (SDSC SHAR)</p>
<p>U1.1</p>	<p>Automated Stage Preparation with minimum human intervention (SDSC SHAR)</p> <p>As the launch frequency increases, human intervention, in repetitive work, will have a tendency for delay and error. In this regard, automated Rocket stage preparation infrastructure with an ability to prepare stages swiftly and with minimum error (Six Sigma accuracy) is a gamechanger. The project can be initiated with automation of the Pneumatic Test Consoles (PTC) which can conduct all the leak tests independently and provide data comparison and data analysis automatically using AI/ML in order to increase launch frequency. Following are the features which the user interface shall have:</p> <ol style="list-style-type: none"> 1. Connect and forget technology for stages. 2. Remote monitoring of live leak test data (Secured Data sharing to different agencies). 3. Machine learning based leak check result interpretation. Saves time and increases launch frequency. 4. Automated presentation and reporting system to streamline data. 5. Failure modes and troubleshooting procedures to pin point leak. 6. Enhanced interchangeability for different stages for different global clients. Increase in utilisation of the facility. 7. Automated T&E, saving facility readiness time. <p>Future implication of AI- Based stage preparation.</p>	

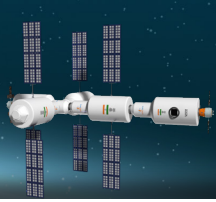

V	Area	Liquid Propulsion (LPSC)
V1.1		<p>Evaluation of Passive Devices for Control of Combustion Instability in Liquid Engines (LPSC)</p> <p>Combustion instability is a phenomenon that sometimes occurs in liquid rocket engines and can lead to damage/destruction of the hardware. It can be controlled by passive techniques such as slots, baffles, resonators etc. It is necessary to model the combustion instability in the presence of these dampeners and evaluate their effectiveness under different operating conditions. The effect of variation of geometric parameters is to be quantified. Combustion instability model for liquid rocket engine with passive dampeners.</p>
V1.2		<p>Development of Physics Based Model to Predict the Soot Formation in the Combustion Chambers of Methane - Oxygen and Isrosene - Oxygen Engines (LPSC)</p> <p>Development of a physics based combustion model to predict soot formation as a function of liquid engine operating parameters such as chamber pressure and mixture ratio. The chemical kinetics, reaction mechanism, species and their desired properties required for combustion modelling have to be formulated through standard published literature for both methane-oxygen and Isrosene-oxygen propellant combinations. The developed model has to be validated with the test data provided by LPSC or with the relevant data available in the open literature.</p> <p>Expected Deliverables are:</p> <p>Quantification of soot formation during methane-oxygen and Isrosene-oxygen combustion in liquid rocket engines. A combustion model to predict the effect of mixture ratio and other operating parameters of the engine on the degree of soot formation.</p>
V1.3		<p>Model based estimation of pressure evolution in a Liquid methane tank ullage with internal feed tunnel under dynamic conditions & cryogenic engine operation (LPSC)</p> <p>Development of discretized mathematical model to estimate ullage pressure and temperature across the ullage volume and calculate the mean mass temperature of the ullage volume during ascent phase & engine operation. The discretized model of the ullage is to be generated for simulating the real time internal thermodynamics & heat transfer phenomena of the ullage during ascent phase & engine operation.</p> <p>The heat transfer modeling in both dome and shell area to be done to estimate the pressure evolution in the tank during the expulsion time of liquid. The node of the ullage is getting increased during the expulsion time and radial and axial heat transfer to be estimated such that the pressure change due to collapsing of the ullage gas due to the exposure of internals during the expulsion of low temperature liquid from the tank.</p>

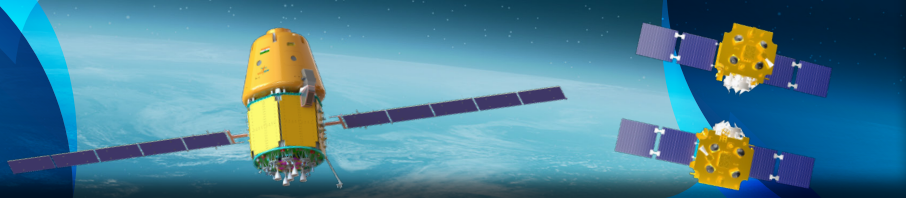

<p>V1.4</p>	<p>CFD modelling of thermal stratification in uninsulated cryogenic propellant tank (LPSC)</p> <p>The LOX and LCH₄ tanks being developed for NGLV are proposed to be uninsulated. The high heat in-leak into the cryogenic propellant will lead to significant vaporization of the propellant and may lead to boiling near walls. Additionally, the frost formation on the tank outer wall determines the heat in-leak into the propellant. Furthermore, the formation of thermally stratified layer near the liquid-vapor interface, evolution of tank pressure and fluid temperature needs to be determined during tank filling process and subsequent operations. Subsequent to lift-off, the aerodynamic loads on the propellant tank will result in fluid sloshing and affect the fluid behaviour and heat transfer to the propellant that needs to be considered in the model. In this regard, a comprehensive CFD model is required to be developed for modeling of the heat and mass transfer phenomena in the un-insulated cryogenic tank during tank filling and lift-off phases. The model must include the frost formation on the tank outer wall, and determine the temperature and pressure evolution in the liquid and vapour in the tank.</p> <p>The CFD model is required to be developed preferably in ANSYS Fluent based on Volume of Fluid method, and must incorporate the mass transfer dynamics of the propellant. The model must be validated with the data available in literature /ISRO's test data.</p>
<p>V1.5</p>	<p>Numerical simulation of single and multiple swirl injector performance in throttleable spacecraft engines (LPSC)</p> <p>Single and multiple coaxial swirl injectors are used in the liquid rocket engines used in propulsion systems of satellites, lunar and planetary landers etc. A part of propellant acts as coolant for the thrust chamber by virtue of the conical spray from the injector. In throttle able engines, the injector spray pattern changes with the change in propellant flow rates, which in turn will affect the cooling of the combustion chamber wall. Further, the wall cooling is also affected by the injector-injector interaction. It is important to understand the injector flow behavior under all operating conditions during design cycle of the engines, prior to hardware fabrication and testing. Simulation of primary breakup of the propellants injected at the nominal and throttles operating conditions is of importance in this regard.</p> <p>Via this proposal it is envisaged to develop a detailed numerical model of primary breakup in MMH/NTO based spacecraft engines which employ multiple coaxial swirl injectors at nominal and throttled operating conditions.</p>
<p>V1.6</p>	<p>Lunar regolith transport from multi-engine firing during planetary descent (LPSC)</p> <p>Planetary descent into an atmosphere-free celestial body generates engine plume flow fields that transition through continuum, rarefied and free-molecular regimes. For multi-engine landers, plume-plume and plume-surface interactions result in complex plume</p>

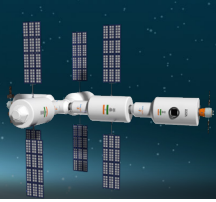

	<p>gas and regolith flow structures. The eroded particle flux from the ground exhibits complex structures as a consequence of the three-dimensionality of the plume flow and plume-plume interactions. The eroded regolith flow resulting from multi-engine landers exhibit directional jetting, where the particles motion tend to concentrate near symmetry planes between adjacent nozzles as well as symmetry planes bisecting each nozzle. Such features cannot be captured using an axisymmetric approach. This research call is for the development of a parallelized three-dimensional two-way coupled DSMC-regolith excitation/transport solver that is capable of simulating the expansion of plume gases from multiple engines of a lander, and their interaction with planetary regolith and the ensuing regolith transport.</p>	
<p>V1.7</p>	<p>Two Phase Flow Modeling in Cryogenic Propellant Feed Lines (LPSC)</p> <p>Cryogenic engines make use of propellants such as liquid Hydrogen and liquid Oxygen at sub-cooled temperatures. The propellant is fed to the engine from the storage tank via. feed lines that are typically of 70-400mm diameter. The feed lines are either super insulated or foam insulated and are initially at ambient temperature ($\approx 298K$). The feed lines are required to be chilled to respective cryogenic temperatures of the fluid ($\approx 20K$ for Hydrogen feed line and $\approx 80K$ for oxygen feedline) prior to the start of engine operation to avoid undesirable flow oscillation. The chill down process is complex in nature due to varying two phase flow boiling regimes and heat-in-leak conditions. In this regard, a validated conjugate numerical model is to be developed to simulate the following:</p> <ul style="list-style-type: none"> • Feedline chill down from ambient temperature to the respective propellant temperature. The model must include heat transfer correlations which will be invoked based on wall temperatures and fluid quality • The model has to capture the effect of pipe orientations viz. horizontal, vertical and inclined on the chill down characteristics • In case of large diameter feed lines, stratified flow predominates and thermal bowing of feedline may occur. The model should be able to capture this flow regime and the associated thermal gradients The time varying temperature evolution of the feedline in axial and circumferential direction and the time taken for feedline chilling completion are some of the important parameters to be compared. The flow regime transition at different points in the feedline. 	
<p>W</p>	<p>Area</p>	<p>Advanced Propulsion Systems and Control Electronics (LPSC)</p>
<p>W1.1</p>	<p>Regenerator Studies on Free Piston Stirling Engine (Fpse) (LPSC)</p> <p>The work aims at optimising the regenerator using the available FPSE with LPSC to achieve highest possible thermal efficiency. The heat transfer in the regenerator is studied simulating the oscillatory nature of the flow. The objective of this is to experimentally measure the friction factors and Nusselt numbers in oscillating flow of regenerator</p>	

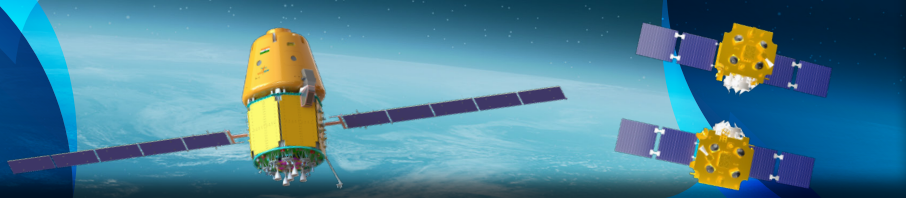

	<p>matrices that will be used in Stirling engines that are planned for space power generation. The experimental data will be analyzed and usable correlations of the friction factor and Nusselt number will be provided. The aim of the study is to optimise the regenerator to enhance the efficiency of the LPSC FPSE from the existing 18-20% (theoretical) by at least 25% using the regenerator.</p> <p>Expected Deliverables are:</p> <ul style="list-style-type: none"> • Optimised regenerator design for the FPSE designed by LPSC.
<p>W1.2</p>	<p>Multi-Plume Interaction Studies of Clustered Hall Thrusters (LPSC)</p> <p>The performance of a thruster in a cluster may be different from a standalone situation. One interest is to investigate the plume interactions, especially in the complex and important nearfield locations. To accurately simulate the plasma plumes from a cluster of Hall thrusters requires an accurate modelling of the complex physical plume mechanism. Traditionally, the computational simulation of plasma plume flows into vacuum is performed with a hybrid particle-fluid approach. The Direct Simulation Monte Carlo (DSMC) method models the collisions of the heavy particles (ions and atoms) while the Particle In Cell (PIC) method models the transport of the ions in electric fields. This study is intended to simulate the detailed three-dimensional plume structures and plume interactions.</p> <p>Expected deliverables are:</p> <ul style="list-style-type: none"> • Simulation of Electron temperature, plasma density and plasma potential profile downstream of single SPT thruster (plume) • Effect of clustering of three SPTs on above plasma parameters • Prediction of overall thrust, efficiency and specific impulse of clustered system
<p>W1.3</p>	<p>Mathematical modelling of Stirling thermoelectric converter (LPSC)</p> <p>Stirling thermo-electric converters have been reported to provide a thermal-to-electrical conversion efficiency of 25-30% in comparison to that of 5-6% for Radioisotope thermoelectric generators. This makes Stirling thermo-electric converters a preferable choice for deep-space missions where the solar energy is insufficient for generation of electrical power. Further, the free-piston Stirling generators with linear alternator are reported to be ideal for use in space due to the clearances between moving parts resulting in their long life. However, the Stirling generators are complex dynamic machines that involve displacer and piston reciprocating at high frequencies (~100Hz) within a cylinder.</p> <p>The mathematical modeling of various heat transfer processes in the heater, cooler and regenerator along with the dynamic motion of fast moving parts in the free-piston Stirling generator with linear alternator is essential for their design, performance evaluation, and optimization for flight use.</p>

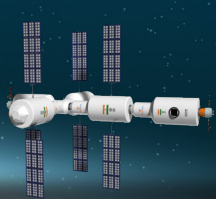

	<p>In this regard, the present proposal is for the requirement of a mathematical model of Stirling thermo-electric converter to simulate the thermodynamic process of the gaseous helium working gas, the various energy losses that take place in the generator during thermal-to-electrical power conversion, and the dynamic forces acting on the moving displacer and piston. The model is required to be generic that can be used for performance evaluation of Stirling generator of various power ratings. The model is required to be validated with the available literature data.</p>	
<p>W1.4</p>	<p>Design and development of high efficiency 5kW rated configurable and scalable converter using wide band gap devices for Aerospace application (LPSC)</p> <p>Design, modeling, simulation, characterization and development of high efficiency (>95% at max power and >90% at minimum power of 500W) 5kW rated configurable and scalable DC-DC converter operating at input voltage of 60-100V and output voltage of 300-600V.</p> <p>Scope of the work:</p> <ol style="list-style-type: none"> 1. Configuration finalization and topology selection. 2. Design and small signal modelling of proposed converter. 3. Characterisation of wide band gap devices (like GaN, HEMT, SiC etc.) for proposed design. 4. Design, simulation and characterization of electromagnetics for proposed design. 5. Configuration studies on control scheme (digital hybrid control) for proposed configuration for meeting configurability, scalability requirements so that converters can be synchronized (in parallel or series combination) and work together to meet the output voltage and power requirements. 6. Implementation of programmable digital control loop gain, current limit, control strategies. 7. Design iterations based on proto model testing and realization of engineering model meeting converter requirements in terms of voltage/power and efficiency requirements. 	
<p>X</p>	<p>Area</p>	<p>Sensors & Transducers for Liquid Propulsion (LPSC)</p>
<p>X1.1</p>	<p>Development of a Quantity Sensing System and Cryo Compatible Electrical Heater for a Cryogenic Super Critical Storage Vessel (Hydrogen & Oxygen) in Space Environment (LPSC)</p> <p>A quantity sensing system and cryo compatible electrical heater for a super critical storage system for Hydrogen and Oxygen is to be developed. The container will be spherical in shape with approximately 1m inside diameter. The storage pressure will be</p>	

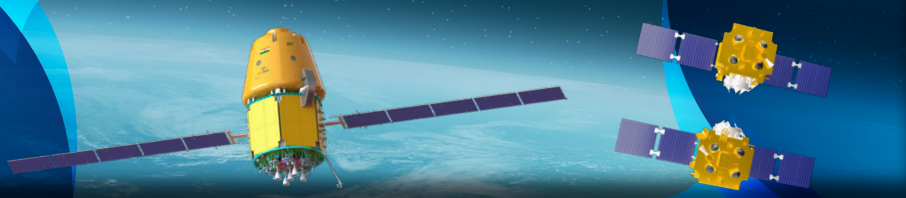

	<p>higher than 1.3 MPa for LH2 & 5.1MPa for LOX. Pressure inside the container shall be maintained above critical pressure using electrical heaters. A cryo compatible electrical heater and an accurate quantity sensing system for cryogenic fluids have to be developed. The sensor system should be able to give dependable results in the following scenario. At ground in the loading condition with the liquid in saturated condition. During operation in space environment with the fluid in super critical phase in varying temperature conditions. The tank pressure will be above critical values. Based on the feasibility, independent proposals can be submitted for quantity sensing system and electrical heater.</p> <p>A capacitance or RF based system is preferred over temperature and pressure-based measurements considering both the operating regimes and preferably single system for different regime.</p> <p>Expected Deliverables are:</p> <ol style="list-style-type: none"> 1. Detailed design, documentation and test results of the sensor / heater system. 2. Working prototype (non-flight) including sensor / Heater.
<p>X1.2</p>	<p>Design and Development of Eddy current based speed sensor for Cryogenic Turbopumps (LPSC)</p> <p>To design and develop an eddy current-based speed sensor with an integrated signal conditioner capable of accurately measuring the rotational speed of turbo pumps in launch vehicles upto LH2 temperature. Presently, turbopumps utilize ferromagnetic-type inducer blades, which are coupled with inductive speed sensors to measure the inducer blade speed, subsequently determining the turbopump speed. However, the increasing demand for lightweight designs in launch vehicle applications necessitates the use of non-magnetic materials like aluminum or titanium for the inducer blades of turbopumps. These materials pose a challenge for conventional inductive-type sensors, which rely on the ferromagnetic properties of the blades for accurate measurement.</p> <p>The objective is to design an eddy current-based speed sensor capable of working with non-magnetic materials such as aluminum and titanium. The sensor should deliver precise and reliable speed measurements for the turbopump, under low-temperature conditions (-253 ° C) that are typical in aerospace environments.</p>
<p>X1.3</p>	<p>Design and Development of Flow Meters Using Fiber Optic Sensors for future launch vehicle applications (LPSC)</p> <p>Flow measurement of propellants such as Liquid Hydrogen (LH2), Liquid Oxygen (LOX) and Isrosene (a semi-cryogenic grade kerosene) is critical for ensuring the proper operation of propulsion systems in space applications. Precise flow measurement of</p>

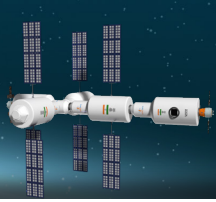

propellants is essential during engine testing, stage filling, and propellant management. Optical fiber sensors, specifically Fiber Bragg Grating (FBG), offer unique advantages due to their high precision, resistance to harsh environments, and ability to operate in extremely low-temperature conditions. Their compact design and lack of moving parts make them well-suited for demanding aerospace conditions. Conventional flow meters often face performance limitations in cryogenic environments due to issues such as thermal contraction, mechanical wear, and susceptibility to electromagnetic interference (EMI).

The main objective is to design, develop, and validate an optical fiber-based flow meter capable of accurately measuring the flow rates of cryogenic/semi-cryogenic propellants under extreme conditions. The developed flow meter should be highly reliable, precise, and able to withstand the demanding temperature and pressure profiles associated with fluids.

Scope:

- Sensor Design: Design a fiber optic-based flow sensor suitable for cryogenic/ semi-cryogenic applications, including material selection and packaging.
- Prototype Development: Fabricate a functional prototype with optical sensing, signal conditioning, and integration hardware.
- Testing and Calibration: Test the sensor using Liquid Nitrogen and calibrate against standard flow meters.
- Performance Analysis: Evaluate accuracy, repeatability, thermal stability, and response time.
- Optimization: Refine the sensor design based on test results for improved performance.
- Documentation: Submit detailed design with know-how documents, test data, and a final technical report.

Y	Area	Materials & Manufacturing for Liquid Propulsion Systems (LPSC)
Y1.1		<p>Forming Limiting Diagram (FLD) Generation and Optimization of Cold forming of KC20WN Cobalt Based Super Alloy for Rocket Nozzle Divergent (LPSC)</p> <p>Presently developmental PS4 divergent with KC20WN material is realised through spinning and welding route in two half and joined together. The present proposal is study the spinning/flow forming of KC20WN to optimise the processing parameters and heat treatments towards realisation of divergent without cir-seam weld configuration.</p> <p>The scope of works includes.</p> <ul style="list-style-type: none"> • Optimisation of spinning/flow forming parameter for KC20WN material towards realisation of nozzle divergent. • Detailed Microstructural and Mechanical characterisation of spun/flow formed KC20WN. • Optimisation of associated Heat treatment process.

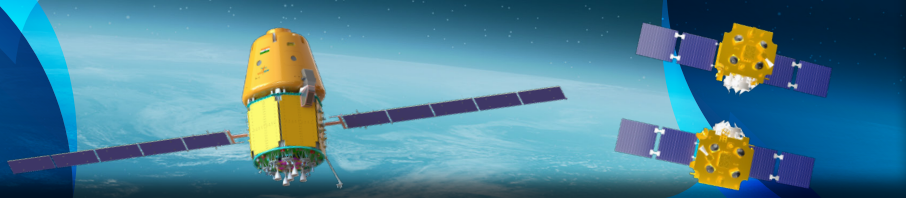

<p>Y1.2</p>	<p>Development of high entropy alloys/high performance alloys for application in solenoid valves (LPSC)</p> <p>Soft magnetic materials presently in use are typically limited to one or two in number. These alloys have limitations in terms of permeability and saturation flux density which hinders device miniaturisation. Also, for high performance alloys available in the market today, poor corrosion resistance restricts their usage. Hence, an optimum alloying composition which would give an optimum combination of soft magnetic properties, good corrosion resistance and strength and also amenable to annealing, is required to be developed. High entropy alloys (HEA)/high performance alloys are the need of the hour. High temperature resistance also may be required for thruster valves directly mounted on the thrusters to be capable of withstanding soak back temperature excursions. The proposed work could involve application of AI & ML tools for the development of a model for identifying the correct material mix for developing the alloy. Modelling and experimentations to occur simultaneously. The model has to be updated and trained based on data availability. Synthesis of the alloy also to form part of the project. Finally the alloy has to be characterised using SEM, XRD and tested for corrosion (for eg. using salt spray method), magnetic and mechanical properties and improvements demonstrated.</p>
<p>Y1.3</p>	<p>Electropolishing of stainless steel and Aluminium alloy parts used in launch vehicle & SC applications (LPSC)</p> <p>Coupon level validation of electro-polishing of various grades of stainless steels like AISI 304L, AISI 202, 430, 15-5 PH & MDN 59 and aluminium alloys like AA6061 T652 & AA7075 T7352 (prior to anodization) as a single substitute for passivation, mechanical polishing & de-burring.</p>
<p>Y1.4</p>	<p>Waveform engineering for MIG Welding power source to reduce residual stress in XH67 Nickel-based alloy (LPSC)</p> <p>Nickel-based alloy XH67 are vital in high-temperature oxygen rich environments but suffer from significant residual stresses during thick section welding, leading to distortion and potential strain age cracking. Waveform engineering in MIG welding, which controls current and voltage patterns, offers a novel approach to mitigate these stresses.</p> <ol style="list-style-type: none"> 1. Investigate the effects of MIG welding waveforms (e.g., pulsed, double-pulsed, modified short-circuit) on heat distribution and cooling rates in nickel-based alloys. 2. Simulate residual stress formation using finite element modeling (FEM) under various waveform conditions. 3. Weld test coupons and measure residual stresses via neutron diffraction/XRD or hole- drilling methods to validate simulations. 4. Optimize waveform parameters for minimal residual stress and high weld quality.

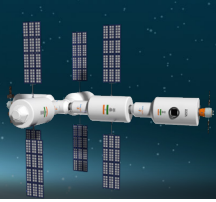

<p>Y1.5</p>	<p>Heat Treatment Optimization for DED and LPBF-Printed Inconel 718 Parts (LPSC)</p> <p>AM processes like DED and LPBF produce Inconel parts with distinct microstructures (e.g., fine grains/ residual stresses) compared to conventional methods. Standard heat treatments may not suffice, requiring tailored approaches to unlock the full potential of AM parts.</p> <ul style="list-style-type: none"> Analyze the as-built microstructure of DED and LPBF-printed Inconel parts using optical microscopy, SEM, and X-ray diffraction. Test heat treatment variables (e.g., temperature, time, cooling rate) to study microstructural changes, including grain growth and stress relief. Optimization of Sub-Critical Annealing for Residual Stress Relief in Laser Powder Bed Fusion (LPBF) Components without Inducing Powder Sintering. Measure mechanical properties (e.g., tensile strength, hardness, fatigue life) of treated samples to determine optimal conditions. Formulate heat treatment guidelines specific to DED and LPBF Inconel parts. 	
<p>Y1.6</p>	<p>Development and Qualification of advanced FSW techniques for welding high thickness AA2219 aluminium alloy for fabrication of launch vehicle propellant tankage (LPSC)</p> <p>Development and qualification of advanced FSW techniques viz. bobbin tool friction stir welding (BT-FSW), robotic FSW, friction plug welding, for welding high thickness AA2219 aluminum alloys (more than 13 mm) for fabrication of launch vehicle propellant tankages.</p> <p>Objective :</p> <ol style="list-style-type: none"> Design and realization of bobbin tool for FSW (BT-FSW) to meet optimum weld strength requirements. Qualification of BT-FSW for welding higher thickness AA2219 aluminum alloys. Qualification of robotic FSW process for higher thickness aluminum alloys. Design and development of friction plug welding process for FSW repairs. Weld parametric studies & preparation of Weld Procedure Specification (WPS) for the aforesaid welding processes. 	
<p>Y2</p>	<p>Sub Area</p>	<p>Non- Destructive Evaluation of Liquid Propulsion Systems (LPSC)</p>
<p>Y2.1</p>	<p>Non-Destructive Residual Stress Assessment in Additively Manufactured metallic parts through Ultrasonic (LPSC)</p> <p>Residual stress can set during Additive Manufacturing, due to cyclic thermal expansion / contraction, which can lead to distortions, cracking, and failure. Amongst the popular methods available for its assessment, ultrasonic methods are non-destructive, portable and have potentiality to apply on actual parts. Few probable ultrasonic approaches</p>	

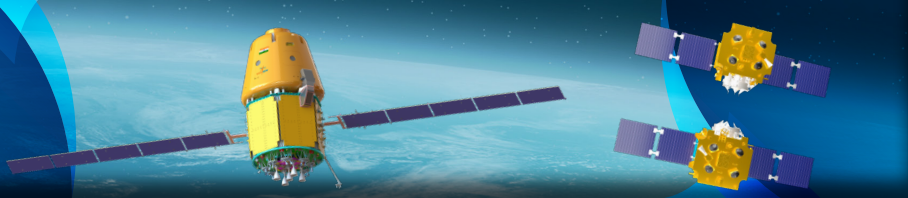

include: measurements of stress-induced longitudinal and shear wave acoustic velocity variations, measuring nonlinear coefficient of critically refracted longitudinal waves etc., to name a few.

The proposal is to establish a viable approach to non-destructively assess the residual stresses using ultrasonics and its implementation on AM parts of various alloy grades viz., In-718, SS316L, AlSi10Mg, Ti6Al4V, Cu-Cr-Zr etc. The objective is to develop a suitable procedure to assess the residual stresses in AM parts using ultrasonics, performing RS measurements on standard specimens as well as parts printed to actual configuration. The results shall be validated using two or more of other established methods such as Neutron Diffraction, XRD, Barkhausen Noise, hole drilling methods etc.

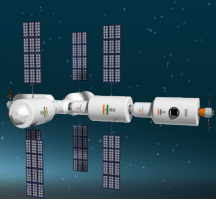

HUMAN SPACE PROGRAMME

A	Area	Human Research, Space Medicine and Space Biology (HSFC)
A1	Sub Area	Personalized Nutrition for Space Diets (HSFC)
A1.1		<p>Macronutrient Optimization (HSFC)</p> <ul style="list-style-type: none"> • Study how India metabolisms (e.g., insulin resistance, lipid partitioning) respond to space food formulations (often designed for Western populations). • Test diets with adjusted carbohydrate-to-fat ratios to mitigate risks of hyperglycaemia or dyslipidaemia in microgravity. • Engineer nutrient-dense, culturally familiar foods (e.g., plant-based proteins, spice-infused meals) to maintain dietary compliance and metabolic health.
A1.2		<p>Micronutrient Supplementation (HSFC)</p> <ul style="list-style-type: none"> • Investigate vitamin D requirements (critical for bone health and immunity), given Indian's baseline deficiency and lack of sunlight in space. • Assess iron metabolism, as Indians may have genetic predispositions to anaemia. • Design nano/micro-carriers to enhance bioavailability of critical micronutrients (e.g., vitamin D, iron etc.) in space food formulations.
A1.3		<p>Gut Microbiome Interactions (HSFC)</p> <ul style="list-style-type: none"> • Analyse how traditional Indian dietary components (e.g., fiber, spices) interact with the gut microbiome in space, which affects nutrient absorption and inflammation.
A2	Sub Area	Exercise Countermeasures (HSFC)
A2.1		<p>Muscle Preservation Strategies (HSFC)</p> <ul style="list-style-type: none"> • Evaluate resistance/weight-bearing exercise protocols to offset Indian's lower baseline muscle mass and higher risk of sarcopenia in microgravity. • Test hybrid regimens (e.g., vibration therapy, electrical stimulation) to enhance muscle protein synthesis. • Carryout muscle atrophy studies on suitable organisms due to microgravity and test of countermeasures.
A2.2		<p>Visceral Fat and Inflammation (HSFC)</p> <ul style="list-style-type: none"> • Study how microgravity exacerbates visceral adiposity-driven inflammation and insulin resistance, and design aerobic exercises to mitigate this.
A2.3		<p>Adaptive Resistance Training Devices (HSFC)</p> <ul style="list-style-type: none"> • Develop compact, microgravity-compatible resistance systems (e.g., electromagnetic or pneumatic-based) to counteract muscle atrophy, tailored to Indians' lower baseline muscle mass.

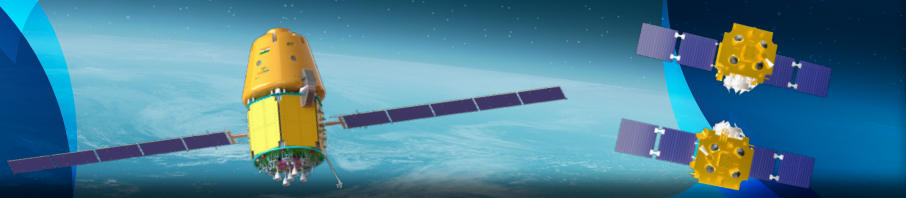

A2.4	Biomechanical Feedback Systems (HSFC) <ul style="list-style-type: none"> Integrate wearable motion sensors with AI-driven feedback to ensure proper exercise form and maximize efficiency in confined spaces. 	
A2.5	Efficacy of yoga and breathing techniques (HSFC) <ul style="list-style-type: none"> Study and develop yoga and breathing protocols to mitigate the effects of spaceflight on human body. 	
A3	Sub Area	Bone Health in Microgravity (HSFC)
A3.1	Bone Loss Mechanism (HSFC) <ul style="list-style-type: none"> Compare bone resorption rates in Indian vs. Caucasian astronauts, given differences in baseline bone mineral density (BMD). Test bisphosphonates or other anti-resorptive therapies adjusted for Indian physiology. 	
A3.2	Calcium-Vitamin D Synergy (HSFC) <ul style="list-style-type: none"> Optimize supplementation to counteract microgravity-induced bone loss, considering genetic variants in vitamin D receptors. 	
A3.3	Mechanical Loading Devices (HSFC) <ul style="list-style-type: none"> Develop platforms to apply controlled mechanical loads on bones, counteracting microgravity-induced bone loss in astronauts. 	
A3.4	Smart Drug Delivery Systems (HSFC) <ul style="list-style-type: none"> Develop biodegradable implants or transdermal patches for sustained release of bisphosphonates, vitamin D, or calcium, tailored to genetic variations in vitamin D receptors common in Indians. 	
A4	Sub Area	Metabolic and Cardiovascular Monitoring (HSFC)
A4.1	Early Detection of Metabolic Syndrome (HSFC) <ul style="list-style-type: none"> Develop biomarkers (e.g., adipokines, inflammatory cytokines) to monitor insulin resistance and ectopic fat accumulation in real-time. 	
A4.2	Cardiovascular Deconditioning (HSFC) <ul style="list-style-type: none"> Study vascular endothelial dysfunction under space stressors (e.g., radiation, fluid shifts) in Indians, who are prone to earlier CVD. Test nitric oxide-boosting interventions (e.g., dietary nitrates) to improve endothelial health. 	
A5	Sub Area	Synergistic Effects of Spaceflight Stressors (HSFC)
A5.1	Combined Stressor Studies (HSFC) <ul style="list-style-type: none"> Simulate spaceflight conditions (e.g., radiation + microgravity + circadian disruption) to assess cumulative impacts on Indian physiology. 	

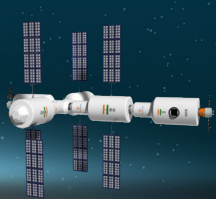

<p>A5.2</p>	<p>Radiation Sensitivity (HSFC)</p> <ul style="list-style-type: none"> Evaluate if Indians' predisposition to oxidative stress (linked to metabolic diseases) increases radiation vulnerability. Carryout radiation studies on extremophiles and murine models for the purpose of studying the effect, inherent protection mechanism and drug efficacy for mitigation including traditional medicines. 	
<p>A5.3</p>	<p>Space Analog studies (HSFC)</p> <ul style="list-style-type: none"> Conduct studies on analog astronauts mimicking spaceflight stressors in understanding physiological adaptation response. Investigate how genetic/epigenetic factors (e.g., thrifty genotype) influence stress responses. Test applicable countermeasures in analog studies. 	
<p>A5.4</p>	<p>Bed rest studies (HSFC)</p> <ul style="list-style-type: none"> Investigate how genetic/epigenetic factors (e.g., thrifty genotype) influence stress responses. Study the physiological and psychological adaptations of Indian astronauts during spaceflight, emphasizing genetic, dietary, and metabolic uniqueness. This should Include studies on bone/muscle loss, cardiovascular deconditioning, and mental health using appropriate microgravity analogs like head down tilt bed rest or dry supine immersion. Test applicable countermeasures. 	
<p>A6</p>	<p>Sub Area</p>	<p>Telemedicine and AI-Driven Diagnostics (HSFC)</p>
<p>A6.1</p>	<p>AI-Powered Predictive Analytics (HSFC)</p> <ul style="list-style-type: none"> Train machine learning models on Indian health data to predict risks (e.g., metabolic syndrome, CVD) and recommend personalized interventions during missions. 	
<p>A6.2</p>	<p>Digital Twin Technology (HSFC)</p> <ul style="list-style-type: none"> Create computational models of Indian astronauts' physiology to simulate responses to space stressors and test interventions virtually. 	
<p>A7</p>	<p>Sub Area</p>	<p>Diagnostic tools (HSFC)</p>
<p>A7.1</p>	<p>Multi-Biomarker Wearable Patches (HSFC)</p> <ul style="list-style-type: none"> Continuously monitor glucose, cortisol, vitamin D, and inflammatory markers (e.g., IL-6) through sweat or interstitial fluid. Integrate flexible electronics with machine learning to flag deviations (e.g., prediabetic trends) and recommend dietary adjustments. 	

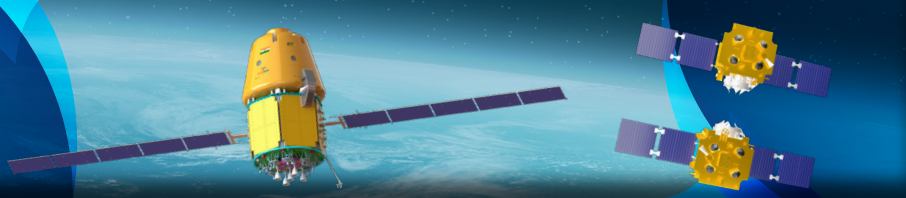

A7.2	Compact Blood Analyzer with Microfluidics (HSFC) <ul style="list-style-type: none"> Perform CBC, lipid profiling, and HbA1c tests using finger-prick blood samples using Microfluidic chips pre-loaded with reagents for anaemia and dyslipidaemia detection having Self-cleaning mechanisms to function in microgravity. 	
A7.3	Breath-Based Metabolic Analysers (HSFC) <ul style="list-style-type: none"> Detect acetone (marker for ketosis), ethanol (gut microbiome imbalance), and nitric oxide (vascular health) in exhaled breath using Miniaturized gas chromatography-mass spectrometry (GC-MS) systems with AI pattern recognition. 	
A7.4	Bone and Muscle Health Scanners (HSFC) <ul style="list-style-type: none"> Develop Portable DEXA (Dual-Energy X-ray Absorptiometry) with features such as Low-radiation, handheld to track bone mineral density loss. 	
A7.5	Gut Microbiome Sequencer (HSFC) <ul style="list-style-type: none"> Develop Pocket-sized DNA sequencer with CRISPR-based detection of pathogenic bacteria. 	
A7.6	Ocular Pressure and Retinal Sensors (HSFC) <ul style="list-style-type: none"> Monitor intraocular pressure (risks from fluid shifts) and retinal changes (early diabetic retinopathy detection) using portable Fundus cameras with auto-diagnostic algorithms. 	
A7.7	Autonomous Dental Diagnostic Tools (HSFC) <ul style="list-style-type: none"> Develop AI-powered intraoral cameras with spectral imaging to identify enamel erosion or gum inflammation. 	
A7.8	Compact, Autonomous Ultrasound Devices (HSFC) <ul style="list-style-type: none"> Develop handheld, AI-guided ultrasound systems with automated probe placement and image interpretation to monitor Visceral fat accumulation, Cardiac function (e.g., ejection fraction, vascular stiffness) and Muscle atrophy (sarcopenia) and bone density loss (osteoporosis). The device should have Anti-drift stabilization for microgravity imaging preferably with Radiation-hardened components and low-power operation. 	
A7.9	3D/4D Ultrasound Imaging (HSFC) <ul style="list-style-type: none"> Develop volumetric ultrasound systems to assess organ morphology (e.g., liver for NAFLD, kidneys for stone risks) in microgravity. 	
A8	Sub Area	Biosignal Processing Research Areas (HSFC)
A8.1	Real-Time Signal Denoising (HSFC) <ul style="list-style-type: none"> Develop algorithms to filter motion artifacts (e.g., during exercise) and electromagnetic interference in spacecraft environments. 	

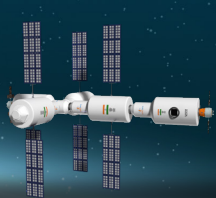

A8.2	Multi-Modal Signal Fusion (HSFC) <ul style="list-style-type: none"> Integrate ECG, EEG, EMG, and respiratory data to holistically assess stress, fatigue, or neurovascular health. 	
A8.3	Artifact Removal in Microgravity (HSFC) <ul style="list-style-type: none"> Address unique challenges like fluid shift-induced signal distortions (e.g., altered blood pressure waveforms). 	
A8.4	Cognitive State Monitoring (HSFC) <ul style="list-style-type: none"> Process EEG and heart rate variability (HRV) to detect mental fatigue or anxiety, triggering VR-based relaxation modules. 	
A9	Sub Area	Microbial Studies in Spacecraft Environments (HSFC)
A9.1	<ul style="list-style-type: none"> Investigation of microbial interactions, biofilm formation & symbiosis in spacecraft environments for improving crew health management & spacecraft maintenance. Study pathogen behaviour and beneficial microbes in closed habitats to prevent infections and enable bioregenerative systems. Characterize microbiome shifts in Indian astronauts. Develop antimicrobial coatings and probiotics. Develop & test new sterilization and decontamination techniques for space missions to ensure the safety & cleanliness of spacecrafts& habitats. 	
A10	Sub Area	Drug Development (HSFC)
A10.1	Drug efficacy (HSFC) <ul style="list-style-type: none"> Study physiological adaptations of Indian astronauts to microgravity and space radiation, with emphasis on medical countermeasures, drug efficacy, and personalized healthcare. Does microgravity alter drug pharmacokinetics (absorption, distribution, metabolism, excretion) in Indian physiology. Can traditional Indian medicines (e.g., Ashwagandha for stress, Turmeric for inflammation) retain efficacy in space. 	
A10.2	Drug stability and packaging (HSFC) <ul style="list-style-type: none"> Test stability of common medications (antibiotics, analgesics) and Ayurvedic formulations in simulated microgravity (clinostats) and on ISRO's microgravity platforms of PSLV and SSLV spent stage, Gaganyaan and future BhartiyaAntariksha Station. Analyse degradation profiles using HPLC/mass spectrometry. Develop novel drug packaging to improve shelf life and efficacy. 	

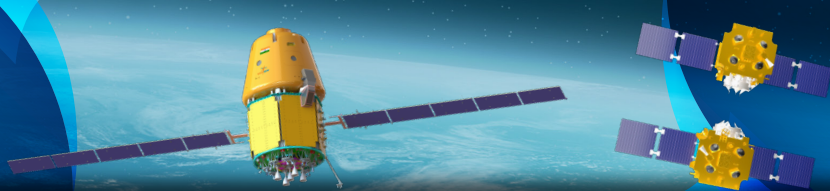

A10.3	Drug delivery(HSFC) <ul style="list-style-type: none"> Develop novel drug Delivery mechanisms for space usage including endodermal patches. 	
A10.4	Traditional Medicine Validation (HSFC) <ul style="list-style-type: none"> Screen and test Ayurvedic formulations for use in space conditions in murine models and humans. 	
A11	Sub Area	Space Biology (HSFC)
A11.1	Cellular & Molecular Biology (HSFC) <ul style="list-style-type: none"> Research on the effects of microgravity, radiation & other stressors on cellular processes, gene expressions & mutations, protein synthesis, cell signalling & tissue regeneration. Explore cellular repair mechanisms, stress responses & aging in the context of long-term spaceflight missions. Develop & refine molecular tools & biomarkers for monitoring cellular health & detecting potential issues in astronauts. 	
A11.2	Plant Biology (HSFC) <ul style="list-style-type: none"> Study plant growth, development & reproduction in space environments to support life support systems & nutritional requirements for long-duration missions. Study plant stress responses & adaptations to spaceflight conditions including changes in gene expression, morphology & physiology. Develop & optimize growth systems & nutrient delivery methods for efficient plant/ crop cultivation in microgravity environments. 	
B	Area	Microgravity Research (HSFC)
B1	Sub Area	Physical & Chemical Science in Microgravity (HSFC)
B1.1	Crew fire safety: Novel methods for fire (smoke) detection and mitigation(HSFC) Flames behave radically different without buoyancy-induced convection of microgravity environment. Hence, the behavior of fire and smoke differs significantly in the confined microgravity environment of a space station, making it critical to develop effective methods for the timely detection and mitigation of fire. This is essential to ensure the safety of crew and protect vital equipment on-board. The scope of this study will involve advancing the understanding of fire behavior in microgravity, and developing novel fire detection/ mitigation methods for space station conditions.	
B1.2	Bubble mitigation strategies for micro-channels (HSFC) Bubble formation is a common phenomenon observed in flow of liquids, especially in a microchannel it becomes a major challenge as it can impede the flow of the liquid. It is important to develop bubble mitigation methods to prevent bubble formation and ensure seamless flow behavior. The scope of this study will involve understanding the bubble formation behavior in micro-channels and develop mitigation methods for the same.	

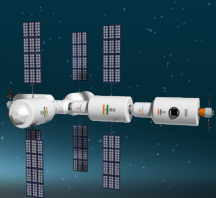

<p>B1.3</p>	<p>Novel strategies for the use of methane in space stations (HSFC)</p> <p>A general method for regenerative environmental control and life support system of space stations is to perform Sabatier reaction and use CO₂ and H₂ in the presence of a catalyst to control the CO₂ levels. This reaction leads to formation of Methane and water. This methane is expelled out of space station using a vacuum exhaust system. However, there may be ways to use this methane for applications and operations on the space station. The scope of work involves studying the physical and chemical aspects of methane usage in microgravity conditions.</p>	
<p>B1.4</p>	<p>Droplet in microgravity: Spreading dynamics, contact-line studies, evaporation, oscillation and spreading (HSFC)</p> <p>Droplets behave in a different manner in microgravity. Many aspects of the droplets such as spreading, contact-line & wettability, evaporation, oscillation and even the shape of droplet have a prominent effect on critical technologies such as development of coatings, combustion, in-situ printing, microfluidics, etc. There is an increased focused on using droplets for studies and development, this spans from droplet-based combustion to droplet – based bio-printing to optimizing industrial processes on Earth. The scope of this study is to investigate the aforementioned aspects of droplets in microgravity to enhance the understanding of droplets in space and assist the development of products and processes designed for microgravity.</p>	
<p>B2</p>	<p>Sub Area</p>	<p>Equipment for Supporting Microgravity Research (HSFC)</p>
<p>B2.1</p>	<p>Development of next generation microfluidic cards with integrated imaging (HSFC)</p> <p>Microfluidic cards are required for conducting research that require automated precise control of fluids. It can be a platform that becomes a habitat for micro-organisms. It can also be used for conducting drug development, developing biosensors, etc. Overall, it is a versatile platform that has multiple applications for studies on space station. The scope of the study involves development of microfluidics card based platform for space, involving identification of bio-compatible materials, microchannel fabrication techniques and integrated imaging methods.</p>	
<p>B2.2</p>	<p>Novel energy efficient refrigeration technologies (HSFC)</p> <p>Biological studies in space station are heavily dependent on supporting equipment. Refrigerators are one of the most power hungry yet essential supporting equipment. The scope of work involves studying novel energy efficient refrigeration technologies meeting envelop, mass and power constraints of typical space station scenario.</p>	
<p>B3</p>	<p>Sub Area</p>	<p>Space Agriculture (HSFC)</p>
<p>B3.1</p>	<p>Development of plant growth habitat for space station (HSFC)</p> <p>A plant-based food production system is crucial for supporting sustained human presence in space, and acts ideal supplement for crew diet. However, growing plants in</p>	

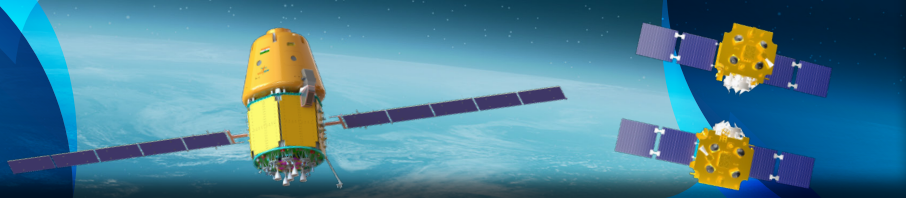

	space requires developing controlled environment for providing water, lighting, temperature, relative humidity, Carbon dioxide, and nutrients in required proportions. The scope of work involves developing plant growth chamber compatible with space station conditions.	
C	Area	Human Spaceflight & Advanced Technology (SAC)
C1	Sub Area	Optical and Quantum Related Technologies (SAC)
C1.1	<p>DWDM based 200 Gbps FSO link demonstration for future Terabit optical communication (SAC)</p> <p>Terabits of data rate will be required for future high-speed links for LEO satellites and Intersatellite links for LEO constellations. Also high throughput satellites require 100s of Gbps data to be transmitted through multiple gateways. RF bands are facing saturation and limited to strict frequency regulation, leading to a requirement of large number ground stations for feeder links. Increasing frequency demand from terrestrial wireless communications also puts restriction RF frequencies and on feeder locations due to signal isolation requirement and practical operational issues. Multiple feeder stations call for multiple terrestrial links involving multiple operators and puts signal security at stake.</p> <p>Technologies developed will be utilized for high data rate links for satellite-based links (LEO –ISL, LEO GEO, GEO-Ground) as well as for optical feeder links for high throughput satellites. A single optical feeder Station can cover vast geographical areas without number of RF feeder stations and their terrestrial links, which requires vast amount of ground infrastructure. These technologies can be extended to Terabits links for future Optical communication and HTS links.</p>	
C1.2	<p>Multi Wavelength Fiber Laser Generation Technique (SAC)</p> <p>Multi-wavelength laser generation from a single source of laser has attracted considerable attention among researchers over the last few decades. The MultiwavelengthFiber Laser Sources have potential Applications in dense wavelength-division-multiplexed (WDM) in High Throughput Satellite in optical communication, optical instrument testing and characterization.</p> <p>Such light sources are particularly in-demand because they provide an efficient and economical solution to increase the flexibility of WDM system. It has various advantage such as low cost and low insertion loss. The requirements for such optical sources are a high number of channels over large wavelength span, moderate output powers with good optical signal to noise ratio (OSNR) and spectral flatness, single longitudinal mode operation of each laser line, tunability and accurate positioning on the ITU frequency grid. Technologies developed in this research will be utilized for optical feeder link for high throughput satellite.</p>	

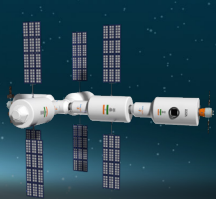

	<p>The scope of the work shall include to explore the several techniques used for multi wavelength generation namely comb filter, cascaded modulation, Brillouin scattering technique, and arrayed waveguide grating.</p>
<p>C1.3</p>	<p>Compact Optical Terminal Development for Optical Inter-Satellite Link (SAC)</p> <p>The upcoming data rate requirement need a paradigm shift from conventional RF satellite link to free space optical link. RF link has some advantage over free space optical (FSO) link where atmosphere is involved. But for inter-satellite link, FSO link is the only viable solution in terms of size, weight and power. The added advantage of FSO link is high data rate, narrow beam width, low EMI/EMC etc.</p> <p>ISRO has initiated the development for FSO inter-satellite link. The base band data will be modulated using optical carrier which has frequency in THz. Using a compact terminal consisting of optical telescope, optical communication subsystems and pointing acquisition and tracking (PAT) mechanism, ISL can be realized. This will also effective reduce the number of ground segment and will add space diversity.</p>
<p>C1.4</p>	<p>Multi Wavelength Fiber Laser Generation Technique (SAC)</p> <p>Multi-wavelength laser generation from a single source of laser has attracted considerable attention among researchers over the last few decades. The MultiwavelengthFiber Laser Sources have potential Applications in dense wavelength-division-multiplexed (WDM) in High Throughput Satellite in optical communication, optical instrument testing and characterization.</p> <p>Microwave Photonic-based on-board processing will be a feasible solution to meet the high-speed processing demand of next-generation broadband satellite system with added advantage of lower mass, lower volume, less power consumption and better EMI performance.</p> <p>The research areas in MWP are Microwave Photonic Filter, Photonic switching and Beam forming. PIC based approach for the above areas are also initiated.</p> <div style="display: flex; justify-content: space-around;"> <div data-bbox="338 1536 884 1872"> <p>The diagram shows a central 'Photronics Based Processor' block. On the left, four input RF signals (RF_{UL,1} to RF_{UL,4}) are multiplexed by a WDM and sent to an FGU. The processor has two sub-blocks: 'Beam-former' and 'Photronics Processor'. On the right, four output RF signals (RF_{DL,1} to RF_{DL,4}) are demultiplexed by O/E blocks.</p> </div> <div data-bbox="938 1536 1484 1872"> <p>The diagram shows a multi-beam payload architecture. It starts with a 'Multi-Feed RX-Ant.' connected to four PSF blocks. These feed into an LNA and then an 'E/O Optical Beamforming' block. This is followed by an 'Optical Processing and Switching' block, then an 'E/O' block, and finally an 'HPA' block. The output goes to a 'Multi-feed TX-Ant.' which is connected to four HRF blocks. A 'PAA' block is also shown. A dashed box labeled 'E/O Block' contains the LNA, E/O, and HPA blocks. An 'FGU' block is also present at the bottom left.</p> </div> </div> <div style="display: flex; justify-content: space-around; margin-top: 10px;"> <div data-bbox="391 1883 837 1964"> <p><i>General Architecture of Microwave Photonics based Processing</i></p> </div> <div data-bbox="970 1883 1455 1964"> <p><i>Photronics based Multi-beam Payload Architecture</i></p> </div> </div>

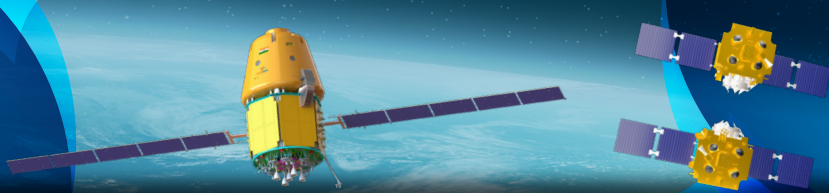

C1.5	<p>High Power Er Doped Fiber Amplifier (SAC)</p> <p>High power optical amplifier (EDFA) is inevitable for the realization of free space optical communication link. This is the device, which amplify the 1550 nm optical signal directly without the need of any electrical conversion. Er- doped fiber is popularly used as the gain medium for optical amplifier. The Pump laser will provide the required population inversion in Erfiber. Different pumping topologies e.g. forward pumping (co-propagation), Backward pumping (Counter propagation) and Bi-directional pumping (Co+ Counter propagation) is explored in the development to maximize the Gain, Saturated power and minimize the noise figure.</p> <p>Fiber fusion and thermal management of fiber plays the crucial role on the operation life EDFA. For any type of optical communication payload, EDFA serves the purpose of power house to sustain the communication link. Though many commercial EDFAs are available, those are meant for ground applications. For space based EDFA, there are lots of design challenges in thermal design, optical fiber assembly, high power electronics aspects. SAC have initiated the in-house development of EDFA in different phases with mid and high power output targets. This development is being carried out in phases. At present 5W output at ambient has been realized.</p>
C1.6	<p>Higher Order Optical Switch For Low Latency Applications (SAC)</p> <p>The increasing user demands required high throughput microwave and optical payloads where onboard signal processing in photonics domain is the most viable option to meet the latency requirements of reconfigurable networks.</p> <p>In photonic switching there are several techniques such as optical MEMS, Semiconductor optical amplifier, waveguide and thermal. In this technology, selection and hardware realization of the switch will be explored which has capability of high switching order (16*16 or higher), switching latency (few nano sec.) in optical C-band. The Cross talk (-40 dBc or better), polarization independent, transparent to data rate up to 10 Gbps with suitable tele command and telemetry provision are the key features of the hardware.</p>
C1.7	<p>Digital Signal Processing for Optical Coherent Receiver in BPSK, QPSK or Advanced Modulation Format (SAC)</p> <p>For advanced optical communication formats e.g. BPSK, QPSK, 8-PSK etc., the post processing of electrical signal is inevitable after detection through coherent receiver with single polarization (X channel) or dual polarization (X and Y channel) multiplexing.</p> <p>Several impairments cause the optical signal distortion and those effects need to counter through algorithm. Main algorithm stage conventionally consists of Bessel filtering, Resampling, Quadrature imbalance, non-linearity and Chromatic dispersion compensation etc.</p>

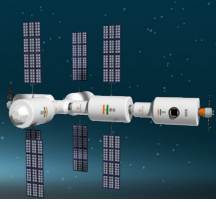

	<p>The data rate is typically more than 10 Gbps. In such high data rate, the DSP using FPGA is very challenging. There is a scope of code development for FPGA to mitigate the effects.</p>
<p>C1.8</p>	<p>High Sensitivity Optical Low Noise Amplifier (SAC)</p> <p>Low Noise optical amplifier (EDFA) is the front end of the optical receiver section and it is inevitable for the realization of free space optical communication link. This is the device which amplify the weak incoming optical signals for the detection by photodiode.</p> <p>Single Mode Er- doped fiber is popularly used as the gain medium for optical amplifier. The Pump laser will provide the required population inversion in Erfiber. Different pumping topologies e.g. forward pumping (co- propagation), Backward pumping (Counter propagation) and Bi-directional pumping (Co+ Counter propagation) is explored in the development to maximize the Gain with minimal added noise figure and improved sensitivity.</p> <p>To improve the link margin for the compact optical terminal the noise floor of the low noise amplifier should be as low as possible to provide the best amplification with minimal noise in incoming modulation signal.</p> <p>SAC have initiated the in-house development of EDFA in different phases and development is being carried out in phases. At present -63 dBm with 50 dB gain at ambient has been realized as the state of the art worldwide.</p>
<p>C1.9</p>	<p>Modeling of atmospheric turbulence parameters using radiosonde data and estimation of localized Fried parameter(r_0) for new OGS location (SAC)</p> <p>Clear air turbulence phenomena affect the propagation of an optical beam because the refractive index randomly varies in space and time. Mainly, random variation of the refractive index of air depends on the air mixing due to temperature variation in the atmosphere. In fact, sunlight incident upon the earth’s surface causes heating of the earth’s surface and the air in its proximity. These effects happen at different points in the atmosphere, and hence it is worth discussing the structure of the earth’s atmosphere briefly. There are many parameters to be considered for the atmosphere but the major points are Refractive index structure constant (C_n^2) & Coherence length (r_0). C_n^2 determines the strength of turbulence and depends on the geographical location, altitude, and time of day. Close to ground, there is the largest gradient of temperature associated with the largest values of atmospheric pressure (and air density), therefore one should expect larger values of C_n^2 at sea level. Typical value of C_n^2 for a weak turbulence at ground level can be as little as $10^{-17} \text{ m}^{-3/2}$, while for a strong turbulence.</p>

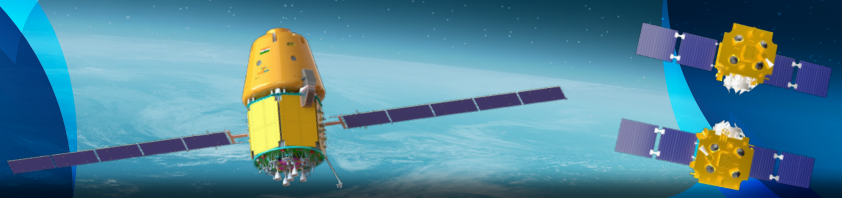

it can be up to $10^{-12} \text{ m}^{-3/2}$ or larger. The refractive index structure constant is related to the temperature structure constant as C_n^2 :

$$C_n^2(h) = 0.00594(v/27)^2(10^{-5}h)^{10} \exp(-h/1000) + 2.7 \times 10^{-16} \exp(-h/1500) + A_0 \exp(-h/100)$$

C_T is the temperature structure constant:

$$C_T = \left(\left((T_1 - T_2)^2 \right) \right)^{1/2} r^{-1/3}$$

Theoretical models of measuring refractive index profile: Hufnagel-Valley Model (HV Model):

$$C_n^2 = \left(\frac{78p}{T^2} \times 10^{-6} \right)^2 C_T^2$$

Where h is the altitude, v is the rms wind speed & A_0 is the turbulence level at ground level.

HV model is generally valid for mid-latitude regions where turbulence such as temperature gradients, humidity and wind speed differ from that of the Indian mainland.

Then defining r_0 which is the diameter of an equivalent aperture where the telescope resolution is approximately the same (diffraction limited) in absence of turbulence: the larger r_0 is the smaller the effects of turbulence on the propagating wave. Also, it depends on Zenith angle, wavelength, structure constant variation, Height, etc.:

$$r_0 = 1.67 \left[\sec(\theta) k^2 \int_{h_0}^H C_n^2(h) dh \right]^{-3/5}$$

where θ is the angle from the zenith in the slant path

As per the above equation turbulence, in a space-to-Earth satellite link one should expect large atmospheric coherence length at the satellite (uplink), and smaller r_0 with more severe phase distortion at the ground station receiver (downlink). We measured the r_0 for Delhi throughout the year using Radiosonde data, which captures variations in temperature and pressure with altitude as shown below.

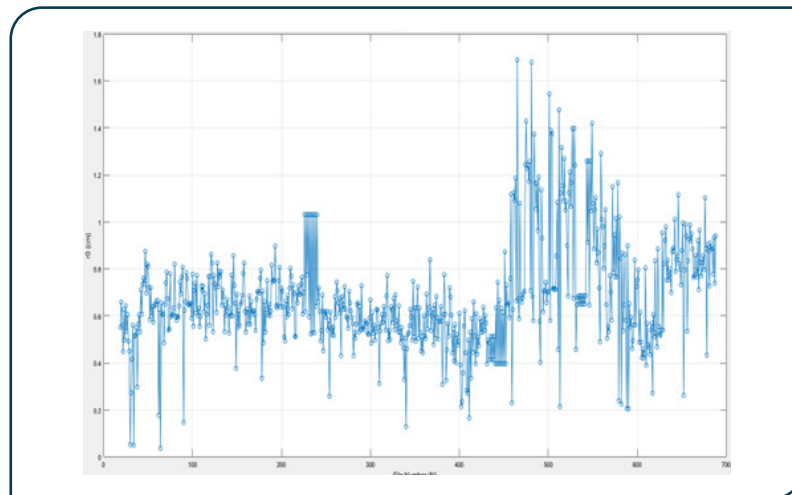

Variation of r_0 for 1 year of Delhi

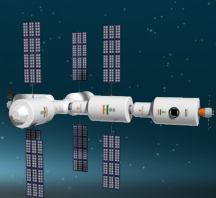

C2	Sub Area	Atomic Clock Related Technologies (SAC)
C2.1		<p>Chip Scale atomic clocks (SAC)</p> <p>Atomic frequency standards are the back-bone of the satellite navigation technology. SAC has developed indigenous atomic clocks for India's navigation programme – IRNSS (NavIC). The key concepts of atomic clocks involve atomic spectroscopy; RF & microwave electronics; microwave cavities; optics; low noise detection schemes and digital electronics. In view of supporting the in-house R&D activities, further detailed theoretical modelling can aid our practical work. Herewith, the following proposed research on theoretical and experimental studies can enhance our activities towards the optimization of atomic clocks.</p> <p>In the Coherent Population Trapping scheme, the use of microwave cavities can be avoided to build atomic clocks. This can, in principle, bring down the size to a considerable extent. The recent advances in chip-scale atomic clocks has been possible due to CPT methods. Research need to focus on development of physics package of chip-scale atomic clocks. Primary area of research include fabrication of Rb/Cs filled micro-fabricated cell, Modulation of VCSEL for CPT interrogation and assembly of VCSEL and Cell along with optics and heaters.</p>
C2.2		<p>Studies on light-shift effects in atomic clocks and analyses of on-board clock jumps (SAC)</p> <p>Rubidium atomic clocks are the widely used clocks in GNSS for space based navigation. These Rb clocks are prone to onboard frequency jumps, which results in the error on the navigation signals. It is of utmost importance to understand the source of the jumps in the Rb clocks. The prima facie understanding has brought to notice that light-shift effect is the main cause of these jumps. However, a detailed study is needed to quantitatively understand the physics behind these jumps. Moreover, in this study the other potential parameters such as the radiation effect, magnetic effects etc. need to be addressed which may result in giving rise to clock frequency jumps.</p>
C2.3		<p>Trapped mercury-ion atomic clock (SAC)</p> <p>The trapped mercury-ion atomic clocks can reach stabilities and drifts, which are 1 and 2 orders (respectively) better than the rubidium lamp based RF clocks. These are strong potential candidates for the future deep space navigation missions alongside the current NavIC missions. The area of research include study, design and demonstrate the trapped mercury-ion-clock physics package meeting state of the art specifications.</p>
C2.4		<p>Extraction of pure elements and their isotopes for atomic clock (SAC)</p> <p>Atomic clocks rely on the precise and stable oscillations of atoms to measure time. Elements are available in naturally occurring compounds. The extraction of pure elements and their isotopes is crucial for atomic clocks to ensure precision,</p>

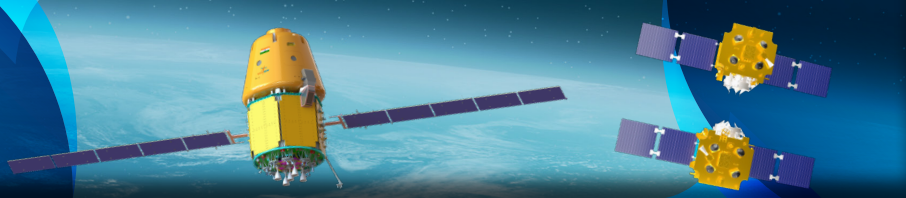

	<p>stability and consistency in timekeeping. Pure natural mix of Rubidium, its isotopes (Rb87 and Rb85) and Mercury isotopes (Hg202 and Hg199) are primarily used in space atomic clock. Detailed research is required to develop efficient methods for extraction and storage of such pure elements.</p>
<p>C2.5</p>	<p>Development of PLL based synthesizer IC for Atomic Clocks (SAC)</p> <p>Frequency Synthesizer is a crucial subsystem to generate precise RF signals in order to interrogate atomic transition levels. Development of PLL based synthesizer IC with low phase noise will greatly help in reducing electronic complexity and realization time of atomic clocks. PLL Synthesizer IC to be developed with 10MHz (sine) input reference should have minimum 2 outputs with following capabilities,</p> <ul style="list-style-type: none"> A. 6GHz to 8GHz or wider main RF output, with a provision to frequency modulate it with input signal of DC to 1KHz. B. 30MHz to 100MHz or wider reference digital (CMOS/TTL/LVTTL/LVCMOS) output for digital electronic circuits.
<p>C2.6</p>	<p>Travelling Wave Tube Amplifier (TWTA) (SAC)</p> <p>It is one of the critical technology elements used for efficient high power amplification in space borne payloads. Amongst all microwave amplifiers, TWTA offers unique combination of power, gain, efficiency and bandwidth.</p> <p>Research opportunity in the field of TWTA is primarily oriented around.</p> <ul style="list-style-type: none"> A. Development of large signal simulation tools. B. Study & development of special UHV grade materials & special coating techniques on UHV material suitable for high temperature brazing. C. Development of methods for texturing on copper surface for reducing SEE. D. Techniques for measurement of high temperature stress & strain in complex shapes. E. Design & development of long life high reliable space cathode. <p>Future research areas include development of</p> <ul style="list-style-type: none"> A. Very high peak power Pulse TWTAs for radar applications. B. Folded waveguide TWTA and Coupled cavity TWTAs for higher frequency band power amplification. C. Brazed Helix technology useful for higher CW power. D. Microwave Power Modules – combination of Solid state amplifier and TWT with advantages of both the technologies. E. Flexible TWTAs for dynamic allocation of frequency, BW & power. F. Filtered Helix TWT with improved harmonic suppression. G. Cold cathodes.

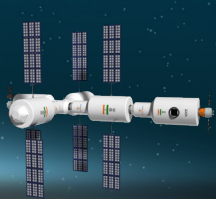

		H. Mini TWT that can be placed right at the back of phased-array antenna. I. High power source that can be beamed to Microwave rockets.
C3	Sub Area	Human Spaceflight Related Technologies (SAC)
C3.1		<p>Human Spaceflight and Advanced Technology Area of ISRO has a well-defined roadmap for conducting space flights with humans and development of technologies to support the missions. Unlike other missions carried out by ISRO so far where mostly observation or service-oriented hardware was flown as payload, HSP will carry humans (as payloads). This creates bundle of opportunities for development of human centric technologies in a large spectrum of domains and disciplines. Some of the technologies fall under the category of 'must haves' while others can be innovative in nature, giving alternatives to existing technologies or enhancing certain aspects of mission.</p> <p>SAC is developing various systems towards HSP where audio, video and text communication systems will enable end to end two-way communication between ground command and astronauts. The technologies involved in this service include following:</p> <ol style="list-style-type: none"> 1. Compact, space qualified camera systems. 2. Baseband units to switch, encode, compress video and audio streams. 3. Noise cancellation based audio communication systems with versions, which can be wearable and can be panel mounted. 4. Modems for RF communications. 5. RF communication network elements like Solid state power amplifiers, switches, filters etc. 6. Antenna systems including phased array antenna. <p>ECLSS (Environmental Control and Life Support System) is system of systems which helps maintain earth like atmosphere inside habitat volume of crew module. This primarily includes maintaining optimal oxygen level, removing carbon dioxide and maintaining PTH (Pressure, Temperature, Humidity). SAC is engaged in developing EMS (Environmental Monitoring System) which measures the values of oxygen and carbon dioxide concentration in cabin environment along with PTH values. Methane and ammonia are by product of metabolism in human body. Carbon monoxide is emitted when something burns. EMS will also measure concentration of these trace gases to keep check on environmental quality and hazard prevention.</p> <p>A portable version of EMS called, HEM (Handheld Environment Monitor) also is developed. Astronauts can use it to check presence of CO2 pockets, origin of trace gases, tracing source of fire, emergency backup of EMS etc.</p>

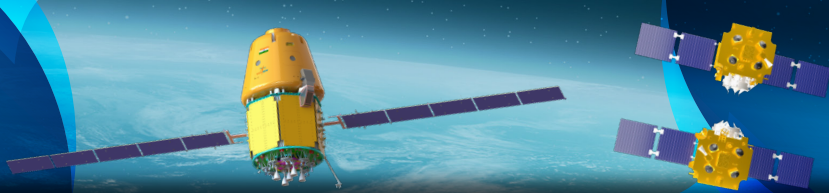

Fire is one of the prominent hazard on board human spaceflight mission. Detection of fire is complex and many pronged approach is needed to evaluate a fire scenario. At the same time, one false alarm can cause unnecessary mission abort. An array of sensors and integration of data from all the sensors is necessary as part of fire detection architecture. UV flame sensors and optical smoke sensors are first line of detection supported by data from thermal cameras and temperature sensors. Change in gas concentration indices also are included in decision making before raising fire alarm. Dousing fire is manual and water mist based fire extinguishers will be used on board this mission.

First point of interaction for astronauts with their module is display system. As primary situational awareness instrumentation, display system receives data from mission computer in the form of parameter values like path, position, velocity and altitude of orbiter module and displays it as combination of graphs, bars and text. Another set of information is Environmental Control and Life-support Subsystem (ECLSS) parameters and medical parameters of astronauts that displays on separate pages. Mission status, date and time, list of tasks, warnings, alarms, text chat, video conferencing etc. are facilitated through display systems. Astronauts can navigate between pages using peripheral buttons on display. They can also command variety of actions using these peripheral buttons, which change its role based on current context or display page.

In addition to large LCD displays, a dot matrix display is developed which will show only critical parameters in alphanumeric formats.

Cabin lights are designed with white LEDs with intensity and color temperature control to automatically sync with time of the day. This feature would help maintain circadian rhythm of astronauts.

The most significant and critical phase of any human spaceflight mission is atmospheric re-entry and subsequent rescue of astronauts at rendezvous point of landing. Various systems are planned and being developed at SAC to support this phase of mission.

Radar Altimeter will be mounted beneath crew module to gauge exact altitude of crew module and pass it to mission computer so that parachutes can be deployed at right moment during descent phase. Location transmitter will read the precise location of landing after splash down through NavIC and GPS and relay the data to rescue team waiting at a safe distance in sea. An LED based high power VFB (Visible Flash Beacon) mounted on top of crew module will aid the rescue team in visibly locating the module in sea. Finally, a satellite phone in hands of astronauts with global coverage gives them ability to stay in touch with mission control even in last mile of mission.

Following areas are identified where academia can contribute directly. Driving factors of development shall be low mass, smaller volume, low power, environmental qualification for space and human rating aspects in design. Introduction of new technologies and

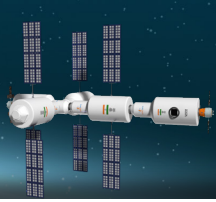

	<p>improvement in existing technologies for HSP, both are seen as potential contribution from academia in this program. Indigenous development of these systems also adds value. The developed technique should also consider feasibility of implementation without affecting any of the existing functional requirements. Reliability aspects are of utmost importance in HSP. Hence, development should target reliability aspects right from concept formation stage and should be followed until building successful prototypes. Certification of every system for HSP is a significant aspect of development. Software used in such systems also undergo spell of certification. Certain design aspects in hardware and software must be built from beginning to aid certification process towards induction of hardware in an HSP mission.</p>
<p>C3.2</p>	<p>Development of measurement systems and sensors for gas concentration (SAC)</p> <p>Human Spaceflight requires continuous measurement of concentration of major air constituents (O_2, CO_2, CH_4, NH_3 & CO) and more than 200 trace gases including trace volatile organic compounds (VOC) at ppm to ppb levels, which are relevant to astronaut's health. These are by-products of metabolism/combustion/chemical reactions in the cabin.</p> <p>Measurement of these gases can be achieved by discrete sensors for each gas or by holistic techniques like spectrometry. Both approaches have their own advantages. Handheld measurement systems can use discrete sensors to build compact, light-weight and battery powered systems. Other techniques can be used to measure array of gases from the same sample. Indigenous development of compact and lightweight sensors and other systems using laser, chromatography, Fourier transform techniques etc. have good potential for present and future applications in HSP.</p>
<p>C3.3</p>	<p>Development of mitigation techniques for Communication blackout during re-entry (SAC)</p> <p>A spacecraft entering the Earth's atmosphere is enveloped by a plasma sheath which results in complete loss or a severe decrease in the strength of RF signals between the re-entry vehicle and the ground. This is referred as Communication Blackout. It results in loss of voice communications and data telemetry during the re-entry of manned space vehicles. The black-out duration can be up to 10-15 minutes and it occurs during the most crucial part of the vehicle's flight. It coincides with the maneuver phase and eliminates ground support during this vital portion of the re-entry phase. In case of an accident during re-entry, this phase is important for post accidental analysis. Due to its criticality, it is important to develop techniques to mitigate this problem. The theoretical study and the analysis should be validated through the practical experiments. Practical experiments may be conducted in the suitable plasma environment to validate the following:</p>

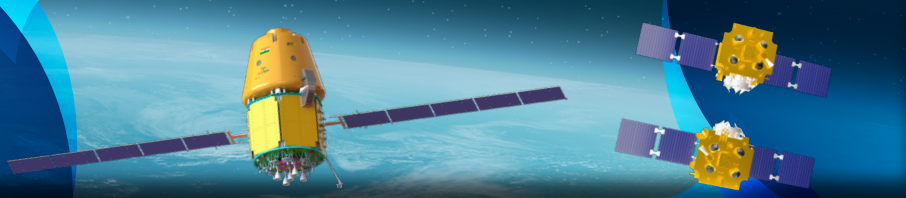

	<ul style="list-style-type: none"> • Dependence of EM wave attenuation on plasma profile. • Dependence of EM wave attenuation on operating frequency w.r.t. plasma frequency. <p>In principle, the most obvious way in which the reentry communication blackout problem can be alleviated is by designing the communications system with a system margin greater than the plasma signal attenuation encountered during reentry. Typical plasma attenuation may exceed 100 dB, thus the required system margin is unrealistically large and cannot be achieved in practice. Hence, other alleviation techniques should be investigated which can be used in conjunction with the system margin. Worldwide many experiments have been done using following techniques to overcome communication blackout:</p> <ul style="list-style-type: none"> • By avoiding attenuation region in plasma sheath: Higher Frequency method. • By reducing concentration of electrons in plasma sheath: Aerodynamic shaping, Injection of coolants. • By altering the properties of plasma to minimize its interaction with the electromagnetic waves: Magnetic Field Method. <p>Development of techniques to enable communication during this phase or to mitigate complete communication black-out can help existing and future missions of HSP. Experiments and finding that can aid to the understanding of phenomenon also can be seen as value addition.</p>
<p>C3.4</p>	<p>Development of wireless communication systems (SAC)</p> <p>Introduction of wireless networking enhances communication in the vicinity of a spacecraft and also facilitates many aspects of communication within a spacecraft including mobile crew monitoring and communication, environmental monitoring and control, structural monitoring, and situational awareness. Wireless system designs should also consider conditions of operational space environment.</p> <p>It is required to develop wireless systems that demonstrate reliable data transfer across avionics components, subsystems, and interfaces to simplify system integration, reconfiguration, and testing. Solutions that enable new avionic architectures and provide capabilities that expand mission performance while decreasing the Size, Weight, and Power consumption and cost of the resulting spacecraft are highly desirable.</p> <p>Applications include sensors communication within habitat volume, communication during Extra Vehicular Activities, video capturing of separation events etc.</p>
<p>C3.5</p>	<p>Active Noise Cancellation for Crew Cabin System (SAC)</p> <p>Due to the presence of various payloads, instruments and other systems, the on-board environment is inherently very noisy. Such high noise exposure for longer mission</p>

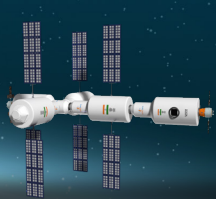

	<p> durations can cause damage to crew hearing system, result in crew efficiency reduction and also hamper with on-going communication.</p> <p>To reduce the effect of continuously present noise on crew communication system, an active noise cancellation system can be designed and developed. With the help of active noise cancellation, resultant noisy environment can be reduced and improved QoS communication can be provided.</p> <ul style="list-style-type: none">• Development of algorithm for Active Noise Cancellation in audio band.• Development of ANC circuitry.
<p>C3.6</p>	<p>Study of In-flight identification and quantification of species in water for long term space missions (SAC)</p> <p>Long Duration Human Spaceflight requires continuous monitoring of water quality to ensure crew health and safety. Water monitoring equipment like colorimetric water quality monitoring kit (CWQMK) are already a part of the ISS. For our future space station and interplanetary travel requirements, it is important to initiate the developments of these systems. These instruments would have immense applications in future space station, interplanetary travel and other long duration space missions.</p> <p>Development of apparatus, test setups for experiments related to above subject, evaluation of data received from such experiments and development of mitigation techniques for observed ill effects can help in current and future missions of HSP.</p>
<p>C3.7</p>	<p>Assessment of flame spread of large scale microgravity fire (SAC)</p> <p>Materials with high flammability must be assessed for the flame spread rate using HEAT AND SMOKE RELEASE RATE TEST (Reference: NASA-STD-6001)</p> <p>Understanding nature of flame, process of combustion, rate of spread, mass consumption, quantity and rate of heat release etc. can be taken up as study. Additionally, apparatus, test setups and identification of methodology, both on ground as well as in micro gravity also is needed to further the understanding of the subject.</p>
<p>C3.8</p>	<p>Microbial monitoring in microgravity environment i.e. Non- culture based in flight monitoring with species identification and quantification (SAC)</p> <p>Microgravity can affect the growth and survival of microbes. The research on this topic is essential to achieve safe and healthy long duration space habitation. Non-culture based in-flight monitoring with identification and quantification of microbial species is targeted for the development.</p> <p>This research would help in understanding the relationship between humans and microbes, which may be affected hugely in microgravity. It will enable the understanding</p>

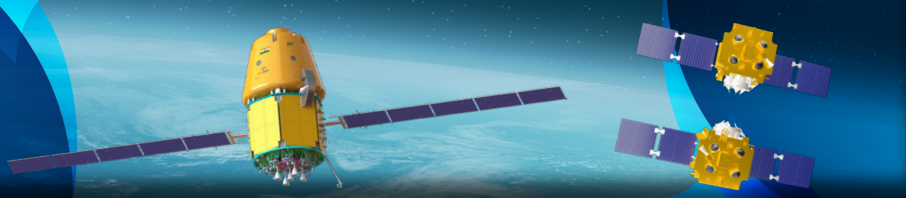

	<p>of how and where microbes proliferate in confined environment in space. Test setups and instrumentation required for remote observations can be developed to achieve the above mentioned purpose followed by findings and conclusions that may become input or directive for future missions.</p>
<p>C3.9</p>	<p>Disinfection technique and technologies for microbial control of water systems and environment in microgravity (SAC)</p> <p>Disinfection and de-contamination are highly essential to achieve safe and healthy long duration space habitation. ISS has a decontamination system which was designed with crew members' safety in mind by using high-power, ultraviolet, light-emitting diodes (UV LEDs) to sanitize surfaces. This cleaning process takes only a matter of minutes before and after the crew conducts the experiments. The sanitation process also removes airborne contaminants -- such as biological and chemical impurities -- and cleans up spills inside the glovebox, providing optimal accommodations for cell science and life science research. It also has an exchangeable glove system that was redesigned to be better suited for these types of studies.</p> <p>These disinfection systems based various technologies like the Ultraviolet Germicidal Irradiation (UVGI) method etc. are essential for long duration space missions/Space Stations for disinfection/removal of microorganisms. Other alternate techniques also can be developed which are safer and more efficient.</p>
<p>C3.10</p>	<p>Application of AI and ML in crewed missions (SAC)</p> <p>Currently, System controls are based on ground based command or crew inputs through button/switch controls which require specific user action. Warning systems are based on predefined criteria and thresholds. AI and ML are relatively in nascent phase as far as space systems are concerned. However, the potential of technique and its application in future cannot be ignored. Hence, exploring possibilities of AI and ML in HSP is encouraged with all potential applications. Some are listed below.</p> <ol style="list-style-type: none"> 1. Voice based system commanding mechanism without restricting/requiring use of any limb action. 2. An early warning system which learns from previous data to warn on possible occurrence of a hazard.
<p>C3.11</p>	<p>Compact fire suppression systems for crewed missions for micro gravity applications (SAC)</p> <p>On board fire in HSP is one of the most serious on-board hazards. Every HSP mission carries fire suppression system. FSS should be safe for humans, should be quick and efficient in dousing fire, should be clean and its application should be safe for onboard electronics. Fine water mist based FSS is in use onboard ISS now. Indigenous development of compact, portable, easy to use and safe FSS is needed for current and future HSP missions.</p>

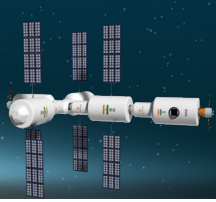

	<p>Research in microgravity is indispensable to disclose the impact of gravity on biological processes, organisms, materials, fire and functional systems. “True” weightlessness, for more than a few seconds at least, can only be achieved in space or zero-g flights in atmosphere. Drop towers, drone based agile platforms etc. have potential to bring out microgravity experiment platform. Test setups, approaches, new ideas to carry-out such tests can be used in existing and future missions of HSP.</p>
<p>C3.12</p>	<p>Next generation fire detection systems (SAC)</p> <p>Fire is one of the most critical on-board hazard for any HSP mission. Detection fire is of paramount importance. Sensors must have very high sensitivity to variety of fire, flame and electric spark. At the same time, it should offer high immunity to false detection.</p> <p>Most mission experiences have reported early detection by humans through smell, rather than on-board sensors. Development of “Electronic Nose” which can detect very low concentrations of combustion products can help in early detection of fire.</p> <p>Fire is detected by measurement of concentration of specific gases, heat, temperature, flame etc. Novel approaches n detection, new parameters that can aid to detection of fire also is needed to enhance the fire detection scenario.</p>
<p>C3.13</p>	<p>Display and other situational awareness technologies (SAC)</p> <p>Visual information (for situational awareness) is made available to the crew either through print pages or displays. A more effective method should allow crew to quickly access context based information.</p> <p>Development can be focused on fixed and portable display devices with higher efficiency (lower size, mass and power) and better human centric aspects, taking advantage of advancement in display panel technology like flexible films displays etc.</p> <p>Augmented reality based devices can be used to provide context based information to the crew for information such as visual alert, holographic communication and object information. AI and ML can be included in such systems to make them more efficient and effective.</p>
<p>C3.14</p>	<p>Instrumentation for docking (SAC)</p> <p>Docking of spacecraft with space station or other manned modules for human or cargo transfer is an autonomous activity in most contemporary HSP missions. ISRO envisages development of these technologies to support automated or assisted docking while in orbit. Laser based or other types of ranging systems, camera based video systems, RF based systems are required for beacons, altimetry or distometry, velocimetry, optical flow techniques, close range photogrammetry and other parameters of situational awareness either in assist mode or in close loop mode for automated docking. Development of sensors, integrated systems and demonstration models can help in future docking missions of HSP.</p>



RESEARCH

AREAS IN SPACE - 2025

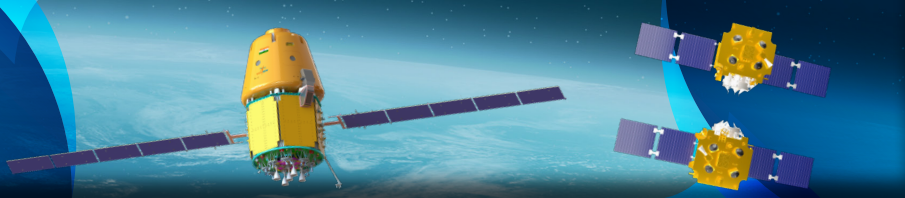

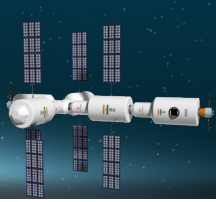

SATELLITE TECHNOLOGY

A	Area	SATCOM and Navigation Payloads (SAC)
A1	Sub Area	System Engineering (SAC)
A1.1		<p>LEO Constellation for Regional Coverage: (SAC)</p> <p>Advance technological changes in satellite communication has led to reduced payload manufacturing cost & launch cost per kg to Low Earth Orbit (LEO) orbit which has made LEO orbit a popular choice for broadband connectivity from space. LEO orbit has major advantage of lower latency and ability to cater smaller user terminals. Broadband LEO constellation can complement the terrestrial networks by serving unserved and improving Quality of Service (QoS) in underserved region. Such networks can be integrated with future technologies like 5G, 6G & Internet of Things (IoT) where connectivity between the devices is a prime requirement, which is major concern for devices located in extreme topography with no terrestrial connectivity.</p> <p>The research areas in this field include:</p> <ul style="list-style-type: none"> • Development of algorithm for inter-satellite link dynamic routing/handover for data downlink/uplink to/from gateways • System studies on integration of LEO broadband constellation & future terrestrial 6G technologies • Development of on-board resource management algorithm based on user demand • System study and algorithm development for LEO-GEO & LEO- Medium Earth Orbit (MEO)-GEO multilayer constellation routing • Development of single aperture multi-beam, compact and light weight antenna integrated with compact lightweight trans-receiver module • Development of compact ISL terminals for LEO-LEO and LEO-GEO communication • Compact ISL terminals for LEO-LEO, LEO-GEO communication: compact optics, pointing and tracking system, optical modulators etc. • Development of translucent/transparent on-board processing digital system based on commercial processor/FPGA technology
A1.2		<p>Software Defined radio based Satellite architectures for Future Satcom systems (SAC)</p> <p>In present scenario, low cost small satellites (Micro or Nano Satellites) are being launched or planned for launch on LEO orbit to provide communication services over the Globe. Small satellites provide an efficient and cost effective solution to different communication services as compared to bigger satellite platforms targeted for GEO orbit. Due to their low mass, power and volume envelope, the payload also has to be designed considering these constraints.</p>

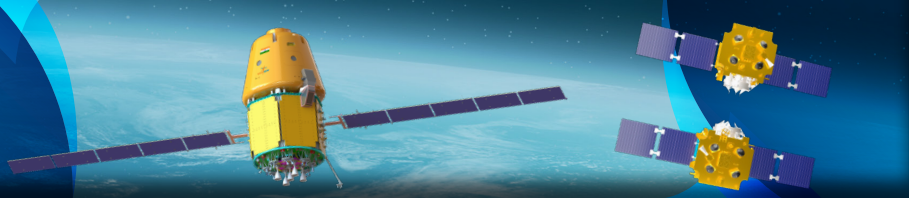

	<p>Software defined radio (SDR) based payload architectures can provide solution for compact/miniaturized design which requires low mass, low DC power consumption & less volume. Present SDR systems can receive/transmit signals directly at RF level up to C-band. This will eliminate the requirements of the complex frontend hardware which in turn provides savings in mass, volume and DC power consumption. SDR based communication payload architecture is well suitable for Indian Nano Satellite Bus (INS) and Indian Micro Satellite Bus (IMS). SDRs will also be useful for future communication payloads for GEO/LEO satellite.</p> <ul style="list-style-type: none"> • Common RF transceiver (single chip/module) having RF front end and Digital subsystems (direct sampling based ADC and DAC modules) to operate from UHF to Ku band frequencies. • Studies and implementation of different signal processing algorithms for regenerative processing and flexibility in terms of channelization and bandwidth. • Development of integrated wideband RF front end with LNA, Bandpass Filters & Precautionary and Liquidity Line (PLL) on RF Transceiver module. • Development of Direct Sampling based ADC and DAC modules which can be integrated with wide band RF front end.
<p>A1.3</p>	<p>Hybrid Satellite/Terrestrial networks and their compatibility with 5G cellular system (SAC)</p> <p>As the spectrum resources are becoming limited and trend is towards delivering high speed data rates in both satellite and terrestrial mobile communication. Hybrid network of terrestrial and satellite systems complementing each other shall be developed for ubiquitous coverage, seamless connectivity and high data rates.</p> <p>Research areas in this direction are:</p> <ul style="list-style-type: none"> • Studies on Satellite – Terrestrial system architecture compatible with 5G Networks • Channel modelling considering both land-mobile and earth-to-space channels • Investigation of Multiple-Input Multiple-Output (MIMO), precoding and other signal processing techniques for enhancing capacity of mobile satellite systems and ensuring coexistence of terrestrial and satellite systems. • Protocol level integration of satellite and terrestrial system and development of satellite-5G testbed. • Investigations on satellite platforms and terminal architectures complementing terrestrial 5G networks.
<p>A1.4</p>	<p>Development of signal processing and resource allocation algorithms for multi gigahertz on-board processors (SAC)</p> <p>With the advancement in signal processing capabilities, the trend is towards channelization and processing of wideband signals covering gigahertz bandwidth.</p>

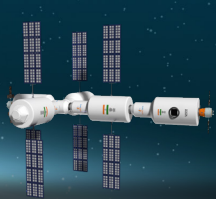

Similarly, the necessity to dynamically and efficiently allocate a communication payload's on-board resources such as power and bandwidth over the desired coverage requires the development of algorithms for beamforming-precoding, beam-hopping etc.

Research areas in this direction are:

- Development of signal analysis algorithms for wideband signals (multi-gigahertz bandwidth). Sparse signal analysis/compressed sensing based algorithms can be targeted.
- Development of translucent processing algorithms which bridge transparent and regenerative payloads through partially decoding packets on satellite.
- Development of algorithms for beam-hopping, digital beamforming, and precoding for efficient spatial allocation of on-board resources.
- Satellite system design and architecture for multi-gigahertz signal processing payload.

Studies on Advanced Navigation systems (SAC)

Satellite navigation has become a key infrastructure element worldwide, enabling numerous applications along with great economic activity. These systems have been conceived as cornerstone of the national security and playing that role effectively. The significance of these systems is evident from the fact that currently there are six global navigation satellite systems (GNSS) which are either operational, under deployment or modernization. The system capability is evolving in both civil and defence domains. Indian Regional Navigation Satellite System (IRNSS) system is now a full-fledged operational system which is providing navigation services over Indian region. The evolving user requirements and global scenario will certainly require continuous research and development to acquire and utilize newer technology in this field. Few such potential areas are enlisted below:

A1.5

- Use of IRNSS signals for navigation with "signals of opportunity" of terrestrial networks.
- Systems studies for autonomous satellite navigation for MEO constellation.
- Development of simulation tools for situation awareness for navigation end users supporting their mission planning. Such tools will consider the complete navigation systems and provide the information about the system accuracy, availability, integrity and reliability for any operational situation.
- System studies on provision of standalone Positioning, Navigation and Timing (PNT) services for the missions on extra-terrestrial bodies like Moon/Mars.
- End-to-end performance analysis of IRNSS signals in LMS channels using software/hardware simulation platform.
- Research on security features of navigation signals such as anti-spoof and message authentication.

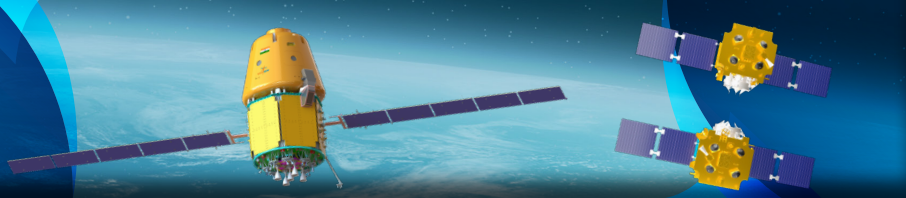

	<ul style="list-style-type: none"> • Studies on navigation signal generation, multi-level signal/sub-carrier design and multiplexing using multicarrier constant envelope modulation schemes. • Studies of various signal modulation schemes like Minimum Shift Keying (MSK), Gaussian Minimum Shift Keying (GMSK), Orthogonal Frequency-Division Multiplexing (OFDM), etc. as potential candidates for the future navigation signals. Studies should also include overall receiver performance analysis for such signals. • Studies of interference mitigation techniques like wavelet based de-noising or other compressive sensing methods on receiver performance. • Research in utilizing space service volume capability of GNSS signals. • Clock ensemble algorithm development for improvement of on-board timing system performance.
<p>A1.6</p>	<p>Space based Automatic Dependent Surveillance-Broadcast (ADS-B) and Automatic Identification System (AIS) (SAC)</p> <p>Automatic Identification System (AIS) is a universal ship-borne terrestrial system used to improve the maritime safety and efficiency of navigation by enabling ship to ship and ship to shore communication.</p> <p>Automatic Dependent Surveillance-Broadcast (ADS-B) is the aircraft surveillance technology in which aircraft provide data such as position, velocity, and identification from on-board aircraft systems.</p> <p>AIS and ADS-B both rely on message transmitted by users regarding their navigation status/location. Space based AIS and ADS-B augment the surveillance capability beyond the terrestrial system range with global coverage (remote, polar and oceanic areas), unrestricted by location. AIS & ADS-B payloads, hosted on low earth orbit (LEO) platforms receive AIS/ADS-B messages, process them and relay them back to ground for usage by service provider to end user.</p> <p>Satellite receives the message from multiple AIS and ADS-B terminal at a same time which causes on-board message collision or messages may get garbled. Since, this is an upcoming area, there are several challenges:</p> <ul style="list-style-type: none"> • Development of On-board algorithm for detect, de-collision and decode of AIS and ADS-B message in low SNR (<9 dB). • Development of low-size, weight and power (SWaP) digital processor. • Development of low noise sensitivity (<-105 dBm) AIS and ADS-B RF front end.
<p>A1.7</p>	<p>Next Generation Data Relay Satellite System (NexGen-IDRSS) (SAC)</p> <p>ISRO has conceived and is developing a Data Relay Satellite System i.e. IDRSS primarily to provide Data Relay Services to Gaganyaan mission. In addition, it is also capable of providing TM/TC services to LEO satellites as well as high data rate relay link from</p>

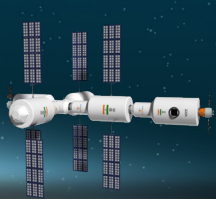

Antarctica. However, IDRSS first generation of satellites are targeted for specific missions. In addition to the services provided by the IDRSS 1st generation satellites, next generation of IDRSS satellites will have enhanced capabilities to provide higher data rate services to a variety of users. Some of the services, which will be targeted through these satellites, are:

- High Data rate relay link from Antarctica station
- Audio/Video/data relay to Human space flight mission.
- High data rate relay from LEO imaging satellites.
- Audio/Video/Broadband Internet services for Bhartiya Antariksh Station.

The payload will require following technologies to be developed to cater to these services:

- Large Deployable Antennas of the order of 4.5 mts in foldable configuration for better G/T and EIRP performance in S-band
- Advanced Phased Array Antenna for targeting multiple LEO satellites for TM/TC operation
- Microwave/Optical Intersatellite links for High Data rate optical communication between satellite to satellite and satellite to ground operation.
- Advanced single channel Mono-Pulse Tracking system.

A1.8

Interplanetary Communication System (SAC)

The recent increase in lunar missions, like landing, manned lunar mission and returning on the South Pole region and demonstration of technologies related to robust thermal systems for the operation of spacecraft for more than one lunar day (~14 Earth days) for exploration of the lunar South Pole region, paves the way for planning future lunar missions. Further, interplanetary missions like Venus and Mars landing missions are also planned by ISRO.

The planned lunar and interplanetary missions would require interplanetary communication system for supporting a moon habitat, high resolution imagery, interplanetary exploration and safety-of-life service for manned missions. The interplanetary communication system requires constellation of small satellites, deep space data relay satellite network and RF beacon system for establishment of high data rate connectivity, local network, connecting with International Mobile Telecommunication (IMT) systems and search & rescue system in emergency situation.

Interplanetary Communication System Network:

Utilization: Support for future human missions to moon and future interplanetary missions with high-speed data communication.

Technologies:

- New waveform, network protocol design as per existing terrestrial standard

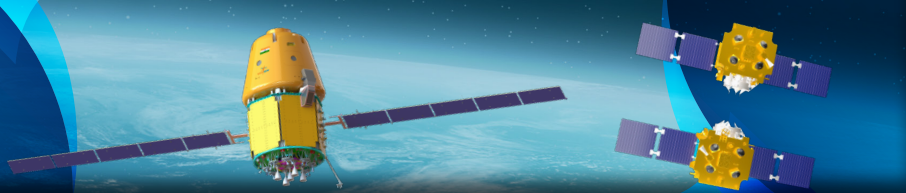

	<ul style="list-style-type: none"> • Interoperable communication system design • Re-configurable, miniaturized antenna/RF/Digital subsystems, advanced one/two-way ranging, orbit determination, and autonomous operation • Tolerance to extreme temp. variation, radiation, vibration, shock, etc. • Satellite aided search & rescue system based on position estimates using Doppler tracking • RF beacon deployment mechanism on the moon or Mars surface • Reliable and continuous communication among lander, rover and orbiter for long-term exploration 	
<p>A1.9</p>	<p>Millimetre-wave Satellite Communication Systems (SAC)</p> <p>The ever increasing demand for data and the proliferation of digital communication devices has led to a spectrum crunch in conventional satcom bands. To increase the available bandwidth for user terminals in Ku and Ka bands, it is proposed to shift the hub frequencies in Q/V bands or W band. While there are several challenges such as limited technological readiness and severe atmospheric impairments, the advantages obtained from freeing a large section of Ku/Ka spectrum are quite significant. Similarly, it is also proposed to have LEO constellations in Q/V bands offering high data rate broadband using small user terminals. Towards this several technologies and studies can be carried out: Research areas in this direction are:</p> <ul style="list-style-type: none"> • Channel modelling and availability analysis for Indian land and Indian ocean regions in Q, V and W bands. • Design of phased array based multibeam transmit/receive antennas for high data rate communication incl. development of beamforming core chips. 	
<p>A2</p>	<p>Sub Area</p>	<p>Digital Systems for Future Communication Satellites (SAC)</p>
<p>A2.1</p>	<p>The current success of satellites is primarily in the fixed satellite services, broadcast satellite services and broadband/internet-related satellite services. In the satellite communication business, the trend for ever-increasing capacity, flexibility and availability of service, as well as increasingly more affordable, more compact, lighter, and even more stylish and ergonomic ground and personal terminals, has become need of the present. It is also believed that satellites in future still play a key role in providing mobile services despite the setbacks that came with early market failures.</p> <p>Onboard digital signal processing has potential for offering innovative satellite services. Availability of space-qualified high-capacity high-speed Field Programmable Gate Array (FPGAs), availability of high-speed Analog to Digital Converters (ADCs) / Data Assimilation Converters DACs and development of specialized-function Application Specific Integrated Circuits (ASICs) have made advanced services a reality. Managing</p>	

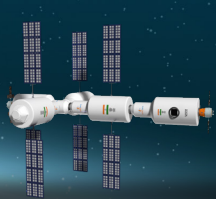

	<p>mass, power, complexity, functionality and reliability for such payload is of paramount importance for offering services at acceptable cost. The emphasis worldwide is on:</p> <ul style="list-style-type: none"> • Increasing the performance (i.e. service availability) • Quality of experience(i.e. less delay) • Reducing cost/bit of information • Efficient use of spectrum • Network integration with terrestrial system • Flexibility (i.e. reconfigurable payloads) • Integration with navigation and observational satellite systems • Security of communication • Resistance to interference and jamming <p>The accomplishment of above tasks would require developing techniques for:</p> <ul style="list-style-type: none"> • Innovative and efficient spectrum processing and sensing algorithms • Innovative techniques, protocols and architecture • Innovative business models <p>The satellite technology is divided in to two major category</p> <ol style="list-style-type: none"> 1. Communication satellite related technology 2. Navigation satellite related technology. 	
A3	Sub Area	Communication Satellite Related Technology (SAC)
A3.1	<p>Advanced Coding and Modulation for Satellite Communication (SAC)</p> <p>Recently the terrestrial communication system of fiber optical cables has grown tremendously. In order to develop a harmonious infrastructure with terrestrial communications systems, the speed of satellite communications must be increased to meet the speed of terrestrial communications system. It is useful to consider a so-called Internet satellite and its development.</p> <p>One generation of 10 years may be long, but it must be reasonable because it may be about a generation of infra structure. An Internet satellite is meant one that provides fixed, broadcast and mobile satellite communications.</p> <p>Current Situation and challenges</p> <p>Most of the communication satellite in ISRO like Indian National Satellite (INSAT) and Geosynchronous Satellite System (GSAT) class of series satellites used mostly Quadrature Phase Shift Keying (QPSK) and Binary Phase Shift Keying (BPSK) modulation system. The reason of using these modulation systems, because of their simplicity and better performance compare to other modulation systems in satellite communication scenario. They are still the popular choice, even in worldwide satellite communication</p>	

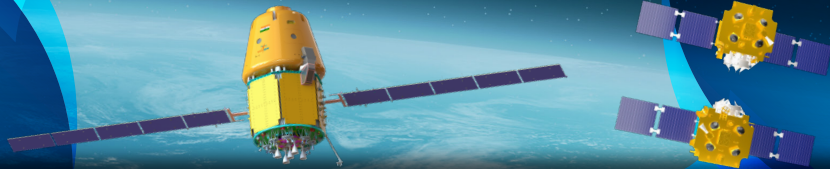

scenario. There are two major approaches for modulator design heterodyne and homodyne. Heterodyne approach basically involves two level of up conversion i.e. the first modulation at Instruction Fetch (IF) label and then up conversion to desire Radio Frequency (RF) frequency. In homodyne approach involves direct conversion from zero IF to desired RF frequency. Till now mostly all major modulator design is based upon heterodyne based approach. But now current state of art design is based upon homodyne approach. Following figures shows direct S and Ka band modulator design for Gaganyaan project. The challenges are left in these modulation are to handle high data rate, where the hardware or component used earlier design will not be useful. The other challenges are reduction of size and power consumption of such system. So, high data rate system using our current modulation scheme with reduces size and power is the current challenges.

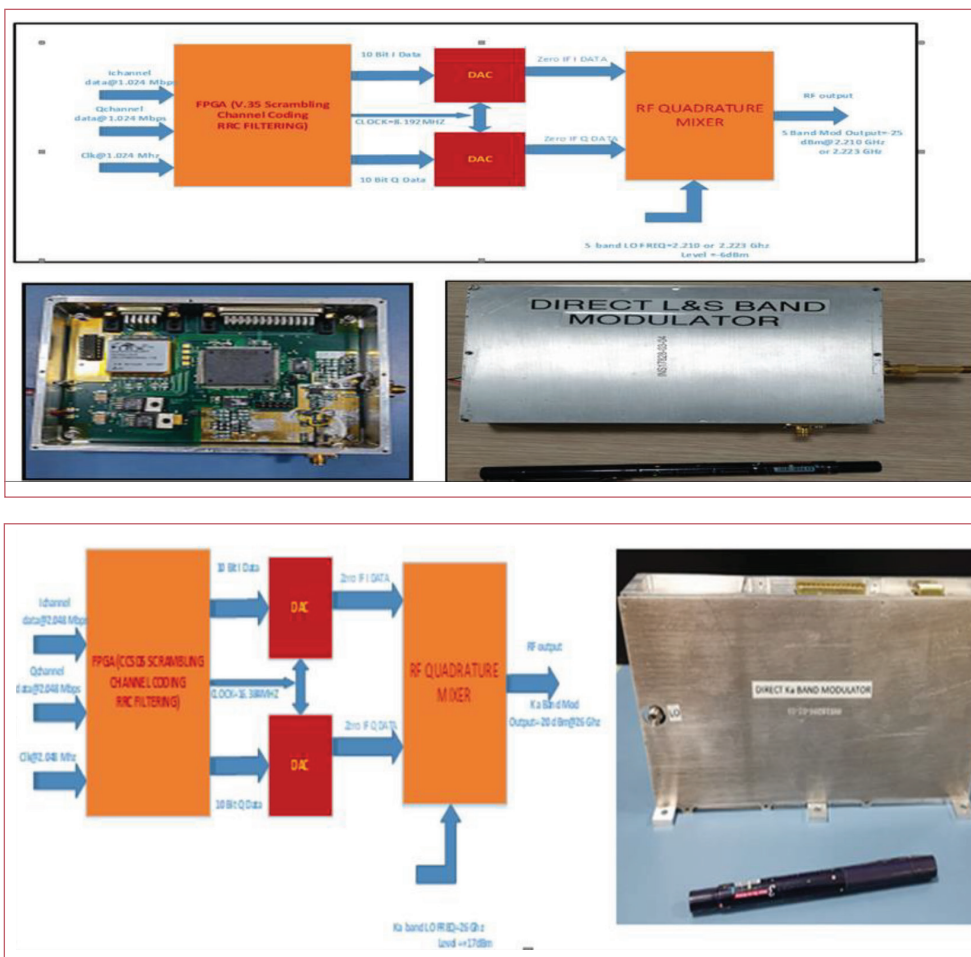

Block Diagram and DVM model of Ka Band Modulator

A3.2

Channel coding for satellite communication (SAC)

The large distance between the transmitting spacecraft and the receiving earth station and the limited transmitting power result in a very poor signal- to-noise ratio at the receiver side. The consequence is a large amount of transmission errors. At the same time, the data bits are highly compressed before transmission to allow as large as possible a

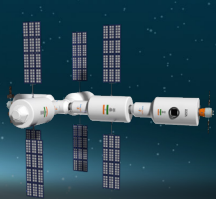

number of images to be transmitted in the limited data rate. But especially compressed data bits are very sensitive to transmission errors. Therefore, channel coding method is also one of the most important technologies.

Current Situation and challenges

Currently most of the satellite made by ISRO used convolutional code with different code rate $1/2$, $3/4$, $7/8$ in concatenation with Reed-Solomon (RS) code in some of the satellite. This type of channel codec works well since last 20 years in satellite communication world. However due to increasing in demand of quality of service and several upcoming deep space explorations, it is now essential that change channel codec for future mission. The Consultative Committee for Space Data Systems has suggested few of the channel code for future satellites and deep space explorations. The current state of the art channel codec is

- Turbo convolutional codes(TCC)
- Turbo product code (TPC)
- Low density Parity check code(LDPC)

New channel coding Scheme

For our satellites and deep space mission Turbo convolutional code and LDPC code are the two main area of thrust for future mission.

- **Turbo Convolution Code**

Parallel-Concatenated Convolutional Codes (PCCC), known as turbo codes, allows structure through concatenation and randomness through interleaving. The Consultative Committee for Space Data Systems (CCSDS) Telemetry Channel Coding Recommendation establishes a common framework and provides a standardized basis for the coding schemes used by CCSDS Agencies for space telemetry data communications. This standard traditionally provides the benchmark for new and emerging coding technologies Turbo codes have an astonishing performance of bit error rate (BER) at relatively low E_b/N_0 . Turbo codes were chosen as a new option for this standard in 1999, only 6 years since their official presentation to the international community: this was the first international standard including turbo codes. The reason was the significant improvement in terms of power efficiency assured by turbo codes over the old codes of the standard. In Chandrayaan-1 mission of ISRO, we have used Turbo convolutional code as per CCSDS standard 131.0-B-1 for low data rate telemetry application. We have also planning to use this turbo code for human space program.

- **Low density parity checks code (LDPC)**

The another important error correcting code, whose performance close to Shannon limit know as low density parity check code. The LDPC code is also a close contender of turbo code. LDPC codes have a remarkable performance with iterative decoding that is very

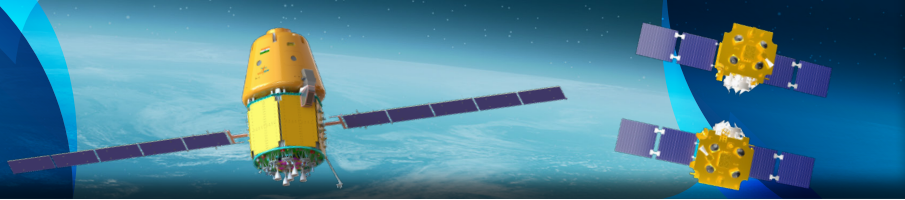

close to the Shannon limit. When compared to the decoding algorithm of convolution code, LDPC decoding algorithm has more parallelization, low implementation complexity, low decoding latency, as well as no error-floors at high Signal-to-Noise Ratio (SNR) as turbo code. The next generation satellite communication systems e.g. digital video broadcast satellite/terrestrial (DVB-S2/T2) have readily adopted LDPC code for Forward Error Correction (FEC), mostly due to its near Shannon performance at very low signal to noise ratio. However, the channel code performance also depends upon the modulation scheme.

The use of advanced channel coding techniques (e.g. TC and LDPC codes) is the state-of-the-art technology used in current satellite systems to provide broadcasting services to fixed terminals in the Ku/Ka frequency bands into two-ways (i.e. Digital Video Broadcasting – Second Generation (DVB-S2) in the forward link and Digital Video Broadcasting – Return Channel via Satellite (DVB-RCS) in the return link, respectively), in which the Additive white Gaussian noise (AWGN) channel is usually assumed. In particular, DVB-S2 considers irregular LDPC codes of either 16200 or 64800 bit code words and 11 coding rates (i.e. ranging from 1/4 to 9/10). With respect to DVB-RCS, double-binary turbo codes are assumed with 12 frame sizes (i.e. ranging from 48 to 752 bit couples) and 7 coding rates (i.e. ranging from 1/3 to 6/7).

Sync word less Concatenated RS and convolutional code encoder and decoder development

The recommended concatenated coding system in satellite communication consists of a Reed-Solomon outer code and a convolutional inner code (which is Viterbi decoded). In typical scenario there is requirement of sync word for synchronization for RS decoder, which lead to reduce the overall efficiency of data transmission and also the overall throughput. The proposed activity will remove the requirement of sync word in each data packet which will improve the overall data efficiency. The proposed activity will be useful for future payload like Gaganyaan etc.

Digital Processors for High Throughput Satellites.

Conventional high throughput satellites employ limited, RF based processing due to unavailability of wideband signal processing hardware. For future high throughput satellites, it will be necessary to employ processing techniques to distribute the on-board resources in an optimal fashion and extract the maximum possible throughput. The relevant research areas would be:

1. Development of system on chip with integrated wideband, direct sampling data converters and RF transceivers.
2. Development of on-board partially or fully reconfigurable, failure tolerant, Multi-core Processor based signal processing system

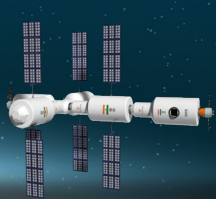

3. Development of multi-channel wideband adaptive signal processing system for digital beamforming and channelization in broadband multi-beam communication payloads.

4. Data compression algorithms for inter-board data communication.

Precoding for V/High Throughput Satellites

Precoding is to counteract the multibeam interface when high/full frequency reuse is employed in V/HTS so that noncomplex UTs can maintain a high Signal to Interference plus Noise Ratio (SINR), even the same carrier frequency is used by adjacent beam. To achieve this precoding employs the channel state information (CSI) toward each UT to mitigate the interference. Signal processing for optimization of precoding matrix and implementation of Precoding function in next generation V/HTS. Some research areas are calculation of Precoding Matrix, and Efficient Implementation of Precoding Matrix in satellite.

A4

Sub Area

Navigation Satellite Related Technology (SAC)

Modulators for Navigation Satellites (SAC)

This Satellite Navigation has revolutionized the navigation world, opening new opportunities in an increasing number of sectors that require high precision. ISRO has taken up the project for the implementation of an independent regional navigation system currently known as Navigation with Indian Constellation (NavIC). The project Indian Regional Navigation Satellite System (IRNSS) envisages establishment of regional navigation system using a combination of Geostationary Orbit (GEO) and Geosynchronous Orbit (GSO) spacecraft's. NavIC is already providing two types of services restricted and unrestricted services or public domain services in L5 and S Band. Binary offset carrier (BOC) and Binary phase shift keying (BPSK) is use for these services. In NavIC, we are using different method for combining these two modulation scheme in order to get constant modulation envelope i.e., the total transmitted power does not vary over time. So that the transmitted information is not contained in the signal amplitude and the transmitted signal amplitude becomes less critical. However, in future NavIC satellite we are going to transmit L1 band signal also for better interoperability and compatibility. In L1 band, we need comply the power spectral density of Multiplexed binary offset carrier (MBOC) modulation. There are other navigation players, who are transmitting their own custom modulation scheme in L1 band. These are mention below.

A4.1

- **CBOC:** The Composite BOC is the solution adopted by Galileo for the Open Service in E1/L1.
- **TMBOC:** The Time-Multiplexed BOC is the solution adopted by GPS for L1C.
- **Quadrature Multiplexed BOC:** Adopted by compass.

A suitable modulation scheme, which comply MBOC power spectral density may design and develop to complete the future requirement.

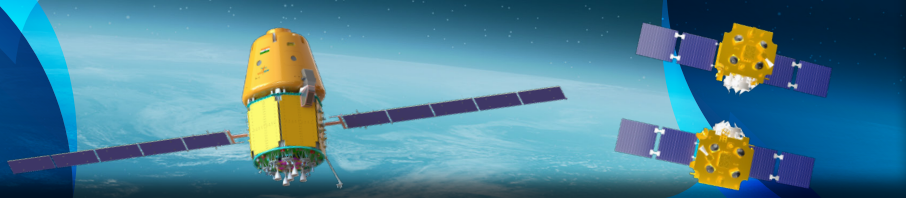

A4.2

Coding Scheme (SAC)

Like other wireless communication signals, navigation signals are subject to noise, multipath and shadowing effects which may induce errors in the received data. Modern navigation signals employ some techniques to detect and correct these errors.

Galileo, modernized GPS as well as space-based augmentation systems (SBAS) (e.g. Wide Area Augmentation System (WAAS), European Geostationary Navigation Overlay Service (EGNOS)) messages make use of FEC. In the following the various error protection techniques used by these systems are described and some details are given for the encoding and decoding processes. The fundamental principle of channel coding is to add redundancy to the navigation message, which is used by a receiver to detect or correct possible errors in the received symbols. The redundant bits added by the encoder are a function of the original information. The original bits may or may not be directly visible in the encoded message. In the first case the encoding is called systematic while in the second case it is called non-systematic.

Channel coding techniques can be further divided into block codes and convolutional codes. Block codes operate on fixed sized blocks of data, each of which are encoded separately, while convolution codes operate on a continuous stream of input data. Both kinds of codes are employed in Global Navigation Satellite System (GNSS), a few of which are detailed in following Table.

CODING SCHEMES USED IN GNSS SIGNALS			
System	Signal	Message	Coding
GPS	L1 C/A	LNAV	none
	L1C	CNAV-2	block: BCH & LDPC
	L2C	CNAV	½-rate convolutional
	L5	CNAV	½-rate convolutional
Galileo	E1-B	INAV	½-rate convolutional
	E6-B	CNAV	½-rate convolutional
	E5a	FNAV	½-rate convolutional
	E5b	INAV	½-rate convolutional
SBAS	L1	SBAS	½-rate convolutional

Recently china (Compass) is also transmitting signal in L1 band having own custom Bose-Chaudhuri-Hocquenghem (BCH) and LDPC codes. In NavIC signal, we are also planning to transmit L1 band signal for better interoperability and compatibility. So there will be a need to develop custom channel coding of navigation signals.

A4.3

Optical Interconnects for High Speed Signal and LO distribution (SAC)

There is a need for High bandwidth (BW) serial data transmissions. Optical Interconnects are required to minimize power consumption, mass and volume. They are practically lossless propagation in an optical fiber within a Digital sub-systems module. The other significant advantages are Immunity to Electromagnetic Interference (EMI) and Electro Magnetic Compatibility(EMC), are mechanically flexible and galvanic ally isolated and provides low phase noise degradation.

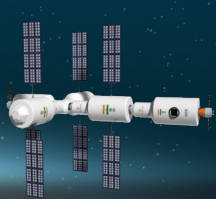

A4.4	<p>High-Performance DSP for Software Defined Payloads (SAC)</p> <p>To meet the requirement of high speed and reconfigure software defined payloads, a high performance Digital Signal Processors (DSP) processor which can meet space electronics quality guidelines are required. Their performance should be benchmarked for following applications</p> <ol style="list-style-type: none">1. DVB-S2 modem: 2 Gb/s transmit, 1 Gb/s receive2. Fast Fourier Transform FFT (complex 16 bit fixed-point): 150 GOPS (Giga Operations per Second)
A4.5	<p>Digital Cancellation Scheme for High-Order Passive Intermodulation Interference (SAC)</p> <p>Passive intermodulation (PIM) is a phenomenon that additional signals at new frequencies (not only the harmonic frequencies) are generated when signals containing two or more different frequencies are processed at the passive devices, such as duplexers, cable connectors, waveguides and antennas. PIM would worsen the antenna gain-to-noise-temperature (G/ T) value, thereby further disrupting the whole system. A full-digital PIM canceling adaptive scheme can be explored based on Least Mean Square LMS algorithm.</p>
A4.6	<p>Onboard Clock Ensemble for clock anomaly handling (SAC)</p> <p>To improve the clock accuracy in future navigation payloads it is required to generate the output frequency signal based on an ensemble of input clocks with optimized performance and improved robustness by clock anomalies handling. Following three algorithms can be developed: Measurement Filtering (MF), based on a cascade of low-pass recursive filters with exponential window functions. Clock Fault Detection and Correction (CFDC), with associated logic based on MF outputs, onboard Clock Ensemble (ONCLE), based on weighted averaging according to filtered frequency information covering clock anomaly handling.</p>
A4.7	<p>On-board Autonomous Orbit Determination of Navigation Satellites using inter-satellite ranging (SAC)</p> <p>Autonomous orbit determination of a navigation constellation is the process by which the orbit parameters of navigation satellites are autonomously calibrated onboard the satellites without the need for external aids. It commonly uses a satellite onboard data processing unit and a filtering method to process the measurements of inter-satellite ranges. The onboard data processing unit is the main module of autonomous navigation systems.</p>

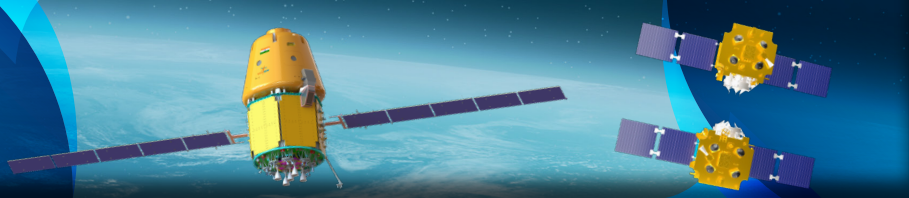

<p>A4.8</p>	<p>FPGA/ASIC Design Methodology (SAC)</p> <p>Following areas for research in FPGA/ASIC Design for onboard signal processing:</p> <ul style="list-style-type: none"> • 28 nm Fully Depleted Silicon On Insulator (FD SOI) to be evaluate for low power Application-Specific Integrated Circuit (ASIC) development for future high speed Digital Subsystems • Formal Verification to Verify Single Event Upset (SEU) Mitigation Techniques for increasing design reliability • High Level Design Methodology for faster design rollout • Linux Operating system for space applications. 	
<p>A5</p>	<p>Sub Area</p>	<p>Development of Ferrite Material for Space Use (SAC)</p>
<p>A5.1</p>	<p>Microwave circulators and isolators are used in communication payloads to improve impedance matching and to avoid multiple reflections. Ferrite material is used in the waveguide junctions because of its non-reciprocal properties, resulting in circulation when magnetized.</p> <p>Understanding the structure of the ferrite material requires knowledge of chemistry, theory of magnetism in ferrites, the non-reciprocal characteristic of ferrite junction at microwave frequencies due to gyromagnetic effect, which involves physics and advanced mathematics.</p> <p>The important properties of a ferrite are:</p> <p>Saturation Magnetization, M_s: This property is related to the spontaneous alignment of electron spins parallel to the applied magnetic field.</p> <p>Gyromagnetic Line width, ΔH: It is a measure of ferrite magnetic losses in the vicinity of ferromagnetic resonance.</p> <p>Effective line width, ΔH_{eff}: It is a measure of ferrite magnetic losses for off-resonance operating points (below and above resonance).</p> <p>Spin wave line width, ΔH_k: It is a measure of attenuation factor of spin waves excited above a power level.</p> <p>Magnetization temperature coefficient, α: It is a measure of relative change in magnetization with respect to temperature.</p> <p>Curie Temperature, T_c: Temperature above which ferrite material has no magnetic properties.</p> <p>The table below shows the ferrite material properties sought for to be used in circulators for space use:</p>	

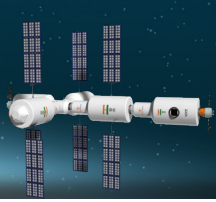

Application	Requirement	Material Property
Low Power Circulator/ Switch	Low Insertion loss, Wide Bandwidth, Compact	Minimum $\Delta H_{eff}, \alpha$ Maximum ϵ M_s as per the frequency
High Power Circulator/ Switch	Low Insertion Loss, High average and peak power handling	Minimum $\Delta H_{eff}, \Delta H_k, \alpha$ M_s as per the frequency High T_c

Research undertaken/to be taken up in Ferrite Devices at SAC

1. Low power and High power Wideband Coaxial circulator
2. High power waveguide circulator at Q-V band and millimeter wave
3. Ferrite Phase shifter
4. High power and low power Ferrite switches

A6

Sub Area

Amplifier Technology (SAC)

A6.1

The microwave and RF amplifiers present in various communication and navigation payloads includes low, medium and high power amplifiers over different frequencies ranging from UHF to Q/V-bands. III-V group (Gallium Arsenide (GaAs) and Gallium Nitride (GaN))based semiconductor technology in the form of discrete RF transistors and Monolithic Microwave Integrated Circuits (MMICs, packaged & unpackaged) are being utilized for the design and realization of high performance solid state amplifier circuits and subsystems.

The next generation satellite communication systems require high output power amplifiers with high efficiency and linearity in small size, low weight having better reliability. To meet the desired performance from amplifier subsystems, control circuits like digital attenuators, phase shifters, voltage variable attenuators, switches etc. are also designed, realized and successfully used in various payloads in the development of channel amplifiers and Solid State Power Amplifier SSPAs. At the lower end of frequency spectrum, at UHF to C-band, availability of GaN technology is offering newer breakthrough in realizing the power amplifiers which may even be replacing Travelling Wave Tube Amplifier (TWTA) in future satellites.

The Indian Regional Navigational Satellite System (IRNSS) provides regional navigation satellite system using a combination of GEO and GSO spacecraft over the Indian region. GaN based SSPA are emerging as a viable alternative to TWT amplifiers especially at L and S-band used in these navigation satellites.

Scope of the work exists in the area of simulation and design of medium to high power compact SSPA with size comparable to TWTA or even smaller. ISRO had already designed, developed and successfully demonstrated communication at Q/V-band in one of its

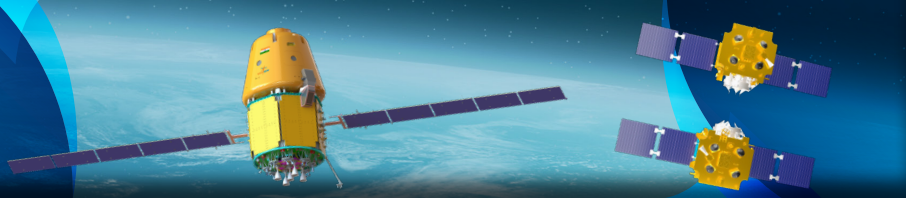

mission. High throughput satellites are being proposed at millimeter wave band in future, requiring further technology development utilizing state-of-the-art techniques in the development of miniaturized driver amplifiers and high power SSPAs with highly efficient RF power combining techniques. There is a requirement of wideband, high power MMIC power amplifier designs upto V-band. To achieve higher power, low loss combining techniques and development of planar or 3D miniaturised RF power dividers and combiners are required at these frequencies.

ISRO had also designed and developed a 2-channel Switch Matrix at Ka-band utilizing high isolation Single Pole, Double Throw (SPDT) switch MMICs and split block assembly. There is research scope in developing state of the art packaging technique for preserving high isolation from such RF switches. There is also research scope in development of thermal modelling and thermal management techniques for high power amplifier MMIC. Multi-function MMIC design & development for driver amplifiers and multi-channel transmit modules are also new areas of research.

Areas of research are:

- Wideband, high power SSPA & Channel amplifiers in UHF, L, S, C, Ku, Ka and Q/V-band.
- GaN based high power compact SSPAs at UHF, L and S-Band.
- High power amplifier GaAs and GaN MMIC designs.
- State-of-the-art technology for design & development of compact SSPA at Q/V-band with waveguide RF interfaces.
- Spatial power combining techniques at millimeter wave frequencies.
- High efficiency Continuous Waves (CW) SSPAs with associated thermal & power management.
- Implementing Efficiency enhancement techniques in S, C, Ku-band Power amplifier.
- Thermal modelling & thermal simulations of MMIC power amplifiers.
- Modelling & simulation of entire amplifier module consisting of MMICs for the effects of bondwires, package cavity etc. on RF performance at Ku-band & beyond.
- Design & development of ASIC for the tele-command interface control circuit for channel amplifier & SSPAs.
- Design & development of high isolation switches and voltage variable attenuators at Ku & Ka-band.

A7	Sub Area	Reconfigurable Filters for Satellite Communication (SAC)
A7.1	The use of reconfigurable payloads in satellite provides significant advantage over current state-of-art satellite configurations. Re-configurability of payload allows for multimode and multifunctional operation. Agility opens the way for reconfigurable	

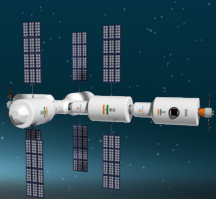

payloads that can be tuned during mission time while in orbit. The ability to reconfigure the operating frequency band offers key advantage to adapt long-lifetime satellites to rapidly evolving user requirements.

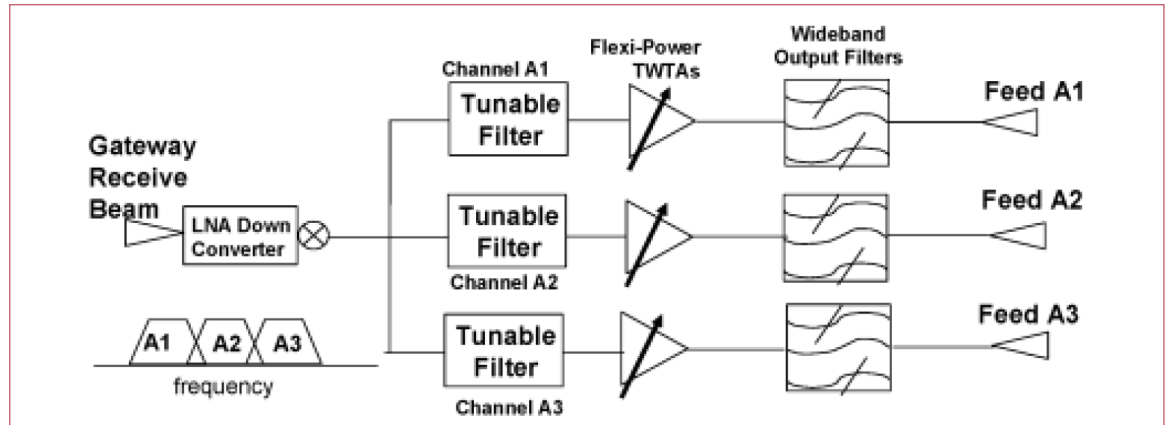

Flexible Payload Configuration

A switchable filter bank can act as alternative solution to a tunable filter where discrete flexibility is required. One such approach, used in the past, employs multiple IMUX and OMUX units, addressing different frequency plans, with extra RF switching functionality to change between them. This solution, however, is costly both in terms of added component costs and the increased mass and volume of the satellite.

Reconfigurable Filters

Microwave Filters used in the communication payload have very stringent in-band and out-of-band requirements. If Tunable/Reconfigurable filters are used to replace these filters in payloads, they must meet these stringent requirements. In particular, they must have High Q, maintain required bandwidth, must have reasonable return loss and should provide required rejections at specified frequency points. These filters should also be able to meet average and peak high power requirements. High Q filters presently used in the satellites are primarily made from 3-Dimensional Waveguide Cavity Resonators, Dielectric Resonators or Coaxial Resonators. Filters made from these resonators meet all the stringent requirements of the payload including high power handling. Depending upon the application, frequency of operation and power handling requirement, one of the above resonator technology is chosen for realizing payload filters. Tunable/Reconfigurable filters required for the satellites will also be required to be realized using these 3D resonator technologies to meet payload requirements. Most of the present day research has been focused on microstrip based tunable filters or SIW based tunable filters. The important constraints related to High power, High Q applications makes these reconfigurable technologies unsuitable for payload applications.

Recently, some progress has also been made in the tunable 3D high Q filters using mechanical motors, piezoelectric actuators and micromechanical switches for aching

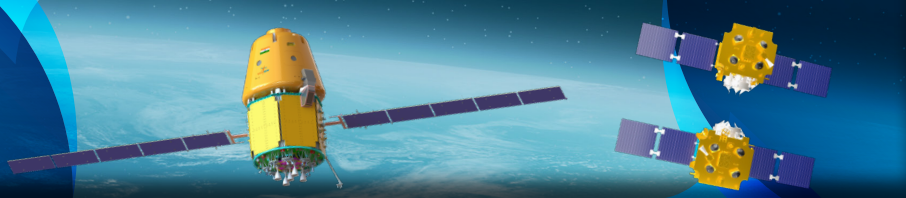

desired tenability. Some of the major challenges involved in the development of such 3D high Q tunable filters are:

- Maintaining required bandwidth and reasonable Return Loss over wide tuning range. Non-uniform variation in resonant frequency of various resonators of the filter and variation in coupling values (External & Internal) of the filter with frequency could lead to degradation in Return loss of the tunable filter.
- Maintaining High Q over wide tuning range. Tuning of resonator over wide tuning range could lead to significant reduction in its Q-factor.
- Ensuring High average power handling capability and required Multipaction margin of 6dB. Implementation of tuning mechanism should not lead to degradation in power handling capability of the filter.
- Qualification of Tunable filter for Space Application. Tunable Filter along with its tuning mechanism, should endure QM level environmental tests.
- Ensuring required Reliability of the tunable filter and its tuning mechanism over its operating life. Reliability of the tunable filter could be impacted due to wear and tear of moving parts or due to increase in the number of parts.
- Minimizing the power consumption and complexity for the tunable filter.

Recent Advances in Reconfigurable Filters:

Though, the optimal design of Tunable/Reconfigurable microwave filter suitable for payload application is yet to be developed, many researchers around the world are at work with this goal in mind. To obtain a tunable cavity filter and thus a tunable mux, the resonant frequencies of the resonators that comprise the filters must be reconfigured. Depending on the resonant mode and its electromagnetic field distribution used in the cavities, this can be achieved by different approaches. These approaches have led to various results in terms of achievable unloaded Q factor, spurious-free tuning range, or mechanical simplicity. Tuning can be performed using mechanical, magnetic, or electrical commands. Some of the recent advances in the field of 3D tunable filter are given below:

Mechanically Tunable waveguide cavity filters (SAC)

a) Bellow-Mounted Tunable Filters (SAC)

Waveguide cavity filters have been widely used in satellites, due to the high-Q and high-power handling capability. In addition, cross-coupled circular-waveguide dual-mode filters, typically operating in TE₁₁₃ mode, offer mass and size reduction and excellent RF performance. Mechanically tunable waveguide cavity filter maintains both High-Q and high-power-handling capabilities. A mechanically tunable waveguide filter can be implemented using bellows. The bellows is a flexible electroformed copper structure which acts as a tuning element. It is a thin-walled (nominally 0.002-in thick) metallic

A7.2

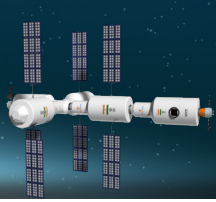

closed-end piston with a designed profile and specific number of convolutions. The bellows-mounted tunable filter offers a very low loss performance over a wide tuning range. A very stable transmission response over a very wide tuning range is also a distinctive feature of this technique. However, there is a tradeoff between RF and mechanical performance when designing a bellows profile. Mechanical operating characteristics are maximized by increasing the number and amplitude of convolutions, whereas RF performance relies on bellows with fewer convolutions.

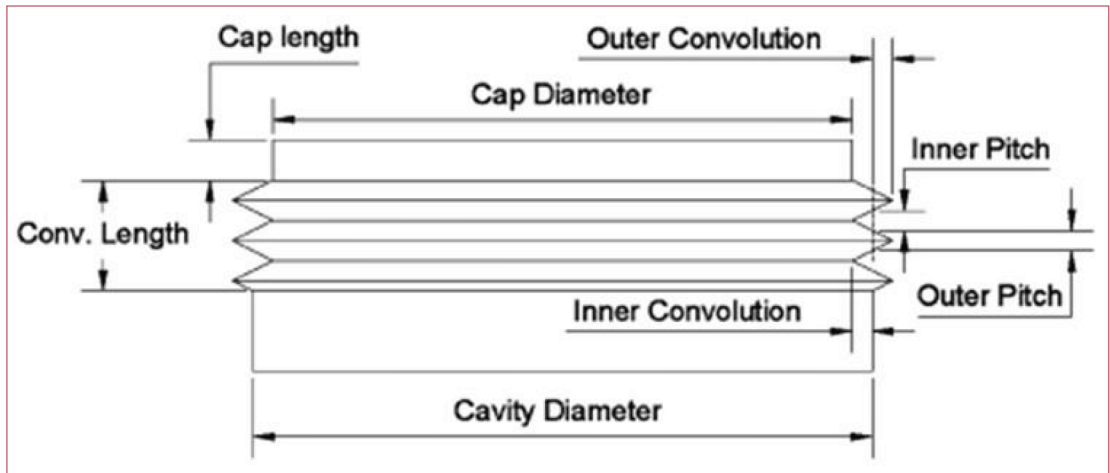

Fully Tunable TE011 Cavity Filters (SAC)

A fully tunable filter for a completely flexible transponder requires tunability of both the bandwidth and center frequency of the filter. RF performance of the filter should be maintained over wide tuning range. In cylindrical cavity filter operating in TE011 mode, electric field strength and current distribution approach zero at the edge of the cavity end walls making it possible to use tuning discs without Q degradation, which in turn leads to the potential for incorporating small and low power consumption motors due to the contactless tuning feature. A movable plunger with diameter smaller than or equal to that of the cavity is used for filter tuning.

The A contactless plunger is used to provide a reactive short-circuit condition at the back of the metal disc ensuring good electrical contact, creating a near shortcircuit condition. This type of plungers consists of quarter-wavelength transformers. The three-section plunger incorporates two low-impedance sections and one high-impedance section. Providing an RF enclosure to the resonator prevents unwanted modes from interfering and degrading the operating TE011 mode. The achieved Q of approximately 10,000 for a Ku band filter is reported in the literature. This design, however, has narrow spurious free window due to presence of low-Q TM111 mode.

A7.3

Coaxial Tunable Filters (SAC)

Coaxial resonators offer moderate-Q and have been implemented for satellite channel-filtering applications. Coaxial technology is suitable for tunable filter applications

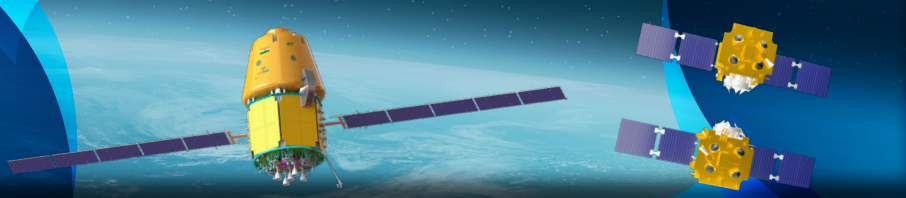

because of the ease of tuning, which is a well-known characteristic of coaxial resonators. A design of a manually tunable coaxial filter is shown in following figure. In this design, Tuning is achieved by rotating a shaped cam above the resonator post which in turn changes the capacitive loading of the resonator. Variation in capacitive loading required for tuning resonant frequency of coaxial resonator can also be achieved by varying the height of tuning disk used at the top of the resonator.

A8	Sub Area	Synthesis and Analysis of Microwave Filters Based on Available Computational Methods (SAC)
----	----------	---

A8.1

To design a microwave filter, synthesis of electrical circuit is required. Synthesis generates complex polynomial for filter transfer function. Coupling matrix synthesis is a popular approach for extraction of the electrical parameters from the complex polynomials. The extracted parameters of coupling matrix are the circuit building blocks for a required filter response realization.

The coupling matrix can be configured/modified for any desired topology of the filter and its corresponding (transmission/Reflection) response. Methods for direct optimization of the coupling matrix for desired transmission/reflection response are also available in literature. Prospective and retrospective use of the coupling matrix for any desired RF response for adaptive resonator topology can be very helpful for time efficient and better electrical performance designs.

Software development for numerical electromagnetic analysis and optimization of standard geometries like rectangular, circular, coaxial resonator based microwave filters with GUI will initiate efforts towards indigenization of Electro-Magnetic (EM) solvers. The scope of software development can be further expanded to more complex geometries. Numerical electromagnetic techniques like Mode matching, Finite Element Method (FEM), Finite-difference Time Domain (FDTD) can be used depending the nature of geometry. The existing Commercial EM tools are highly expensive and hence good amount of foreign exchange can be saved after successful completion of this activity.

Reflectionless Microwave filter

A long-overlooked opportunity to enhance the signal-to-noise ratio (SNR) and dynamic range within a signal chain and to reduce harmonics/spurious content within these circuits is to address a seemingly innate property of filters: their out-of-band reflective behaviour. Reflectionless filters utilize a novel circuit topology to effectively eliminate the standing waves created by traditional filters without additional components (such as pads). This unique property gives designers a new way to improve the system performance of a wide array of broadband circuits, or any circuits suffering from out-of-band impedance mismatch. The typical performance of conventional filters (reflective filters) only exhibited a matched impedance at its ports within the filter's pass-band.

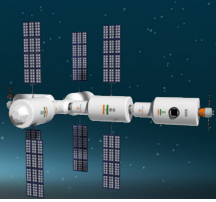

The stop-band regions of these filters are intentionally designed to have very poor impedance match. As a result, undesired stop-band signals, including harmonics, interference, and noise, are all reflected from the filter ports back through the signal chain. If these unwanted signals are reflected back to another reflective device, a standing wave effect emerges. This standing wave will persist and build on itself until the attenuation of the transmission path between the two reflective components dampens and absorbs the unwanted signal energy. The reflectionless filter is a set of filter topologies and designs that inherently exhibit a broadband matched impedance. The major advantage of reflectionless filter topology is that these filters are readily cascadable, so sharper roll-off and greater stop-band rejection may be achieved by adding filters as modular building blocks. The figure below shows the improvement of the receiver chain with the introduction of reflectionless filter.

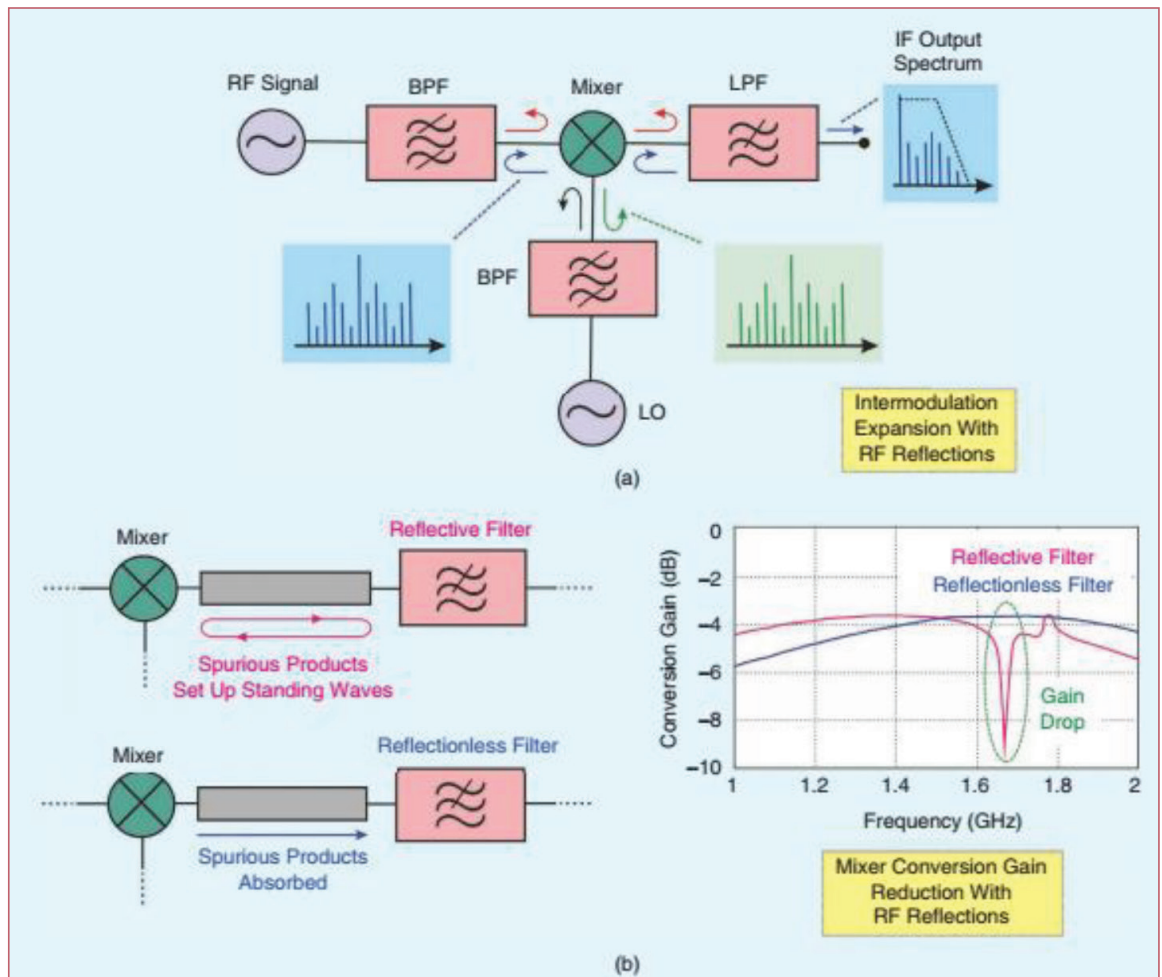

The problems of (a) intermodulation expansion in a receiver's low-conversion stage due to multiple out-of-band RF signal power reflections produced by reflective-type filters and (b) mixer conversion gain reduction resulting from generated standing waves in interconnection transmission lines. LPF: low-pass filter; IF: intermediate frequency.

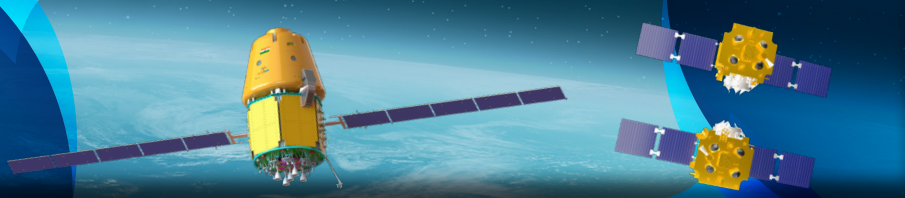

Recent Advancements

Reflectionless Bronchopleural Fistula (BPF) devices developed mostly in planar realizations. However, to much lesser extent they are also have been demonstrated in other technologies. Below are the technologies where nonplanar reflectionless BPF components have been demonstrated are shown in figure:

- 1. MMIC and low-frequency technologies:** Reflectionless BPFs in MMIC technologies are demanded for modern, energy-efficient, compact RF front-end chains. A theoretically perfectly matched symmetrical BPF network with even- and odd-mode subcircuit compensation, an integrated, passive, two-port absorptive BPF is developed. This prototype exhibits a quasi-elliptic-type bandpass filtering response centered at 2.5 GHz with return loss levels above 15 dB from dc to 10 GHz for a chip area of 1 mm². It should be noted that commercial counterparts of this solution are already available showing promise for deployment in future RF transceiver modules. On the other hand, although, thus far, they are used only in low-pass filtering components (which can be easily extended to BPF ones after appropriate lowpass-to-bandpass frequency transformations), the novel classes of reflectionless filters for very low-frequency applications. The future need is to demonstrate and extend this concept for Ku and Ka-band.
- 2. Acoustic wave technology:** BPFs in acoustic wave realizations are leading frequency-selective devices in mobile communications systems, due to their high quality factor (Q) and compact footprint. However, most show some major limitations in terms of their very narrow operational bandwidth and frequency-static filtering transfer function being mostly of the reflective type and because of their spurious mode creation. By efficiently combining the acoustic-wave lumped, element resonator (AWLR) concept presented in for enhanced-bandwidth, quasi-elliptic-type BPF realization with the complementary diplexer approach.
- 3. Multilayer technology:** The exploitation of microstrip-to-microstrip vertical transitions with slot line resonators in multilayer schemes has proven its potential in the development of ultra-wideband BPFs aimed at broadband and RF receivers. Using this concept and the lossy-stub-loading philosophy for reflectionless BPF design, new ultrawideband BPFs that simultaneously exhibit a very broad, symmetrical, reflectionless behaviour can be developed shown in figure.

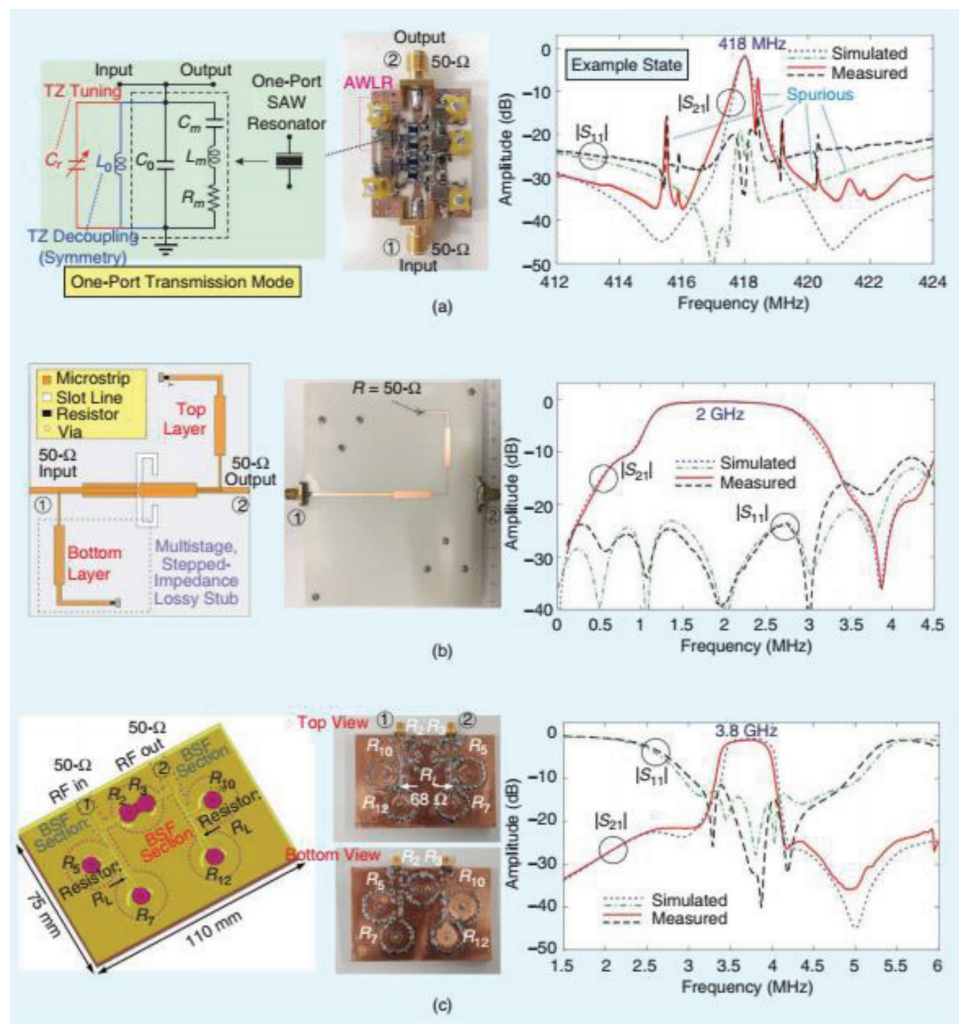
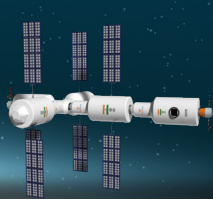

Examples of reflectionless BPFs in nonplanar technologies. (a) An input reflectionless AWLR- based BPF using a complementary diplexer approach for TZ tuning. (b) A symmetrical, reflectionless, wideband BPF on multilayer technology using input/output multistage lossy stubs. (c) A symmetrical reflectionless BPF with substrate-integrated coaxial resonators using a two-port complementary diplexer approach.

Ceramic filters

As the name implies, RF & IF ceramic bandpass filters are manufactured from ceramics that exhibit the piezo-electric effect. One of the most common ceramics used is known as Lead Zirconate Titanate (PZT), lead zirconium titanate. The ceramic element uses its very high Q mechanical resonances to provide the resonant feature. They have bandwidths that are typically measured between 0.05 and 20% of the operating frequency. Often the Q levels range between around 500 up to 10 000.

Ceramic filters are electronic components that are widely used in IF and RF bandpass filter applications for RF circuit design in radio receivers and transmitters and the like. They may also be used as resonant elements in a variety of electronic circuit designs.

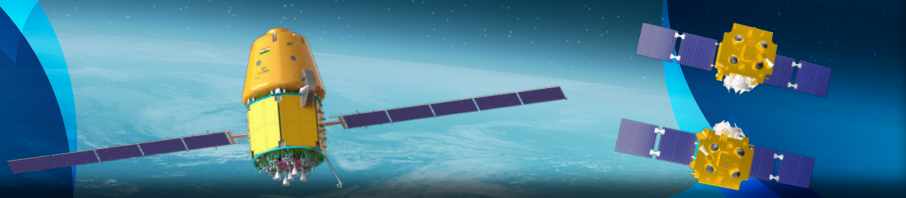

A9	Sub Area	Receiver & Frequency Sources Technologies (SAC)
A9.1		<p>Compact, low power consumption and small volume are the system requirements of all times. In this direction a major emphasis and thrust has been provided over the years for development of miniature Low-Noise Amplifier LNAs, Receivers and Frequency converters over frequencies ranging from UHF to Q/V band. MMIC technologies combined with advance packaging techniques are being utilized for various communication and navigation payloads. Higher operating bandwidths and gain requirements combined with stringent spurious performance poses a challenge for development of compact systems as stringent filters are also to be incorporated.</p> <p>Areas of Research are:</p> <ol style="list-style-type: none"> 1) Beam Forming Receiver 2) Receiver Design for Doppler Shift 3) Flexible Receivers in terms of frequency and bandwidth 4) Design and development of RF switches, Variable Valve Actuation (VVA) and Video Graphics Array (VGA) upto Q/V band 5) Fully integrated Receiver (RF, Local Oscillator (LO) & DC/DC in single package) 6) Medium Power Beacon Sources 7) Design of Synthesizer Integrated Circuit (IC)s
A10	Sub Area	Electronic Power Conditioners (SAC)
A10.1		<p>Electronic Power Conditioners designed to supply power in wide range for RF (Transmit and receive section) and Digital Processors of communication and navigation payloads. EPCs are designed with efficient power conversion topology, high switching frequency, EMI mitigation, low output noise, output voltage sequencing, load sharing, temperature compensated output voltages and categorized as miniaturized low power for RF front end, highly efficient high power for power amplifiers and high peak current channelizer for digital processors. EPC from 1 W to 650 W output power designed and developed for space applications are modular HMC based EPC card embedded in Receiver package, EPC for dynamic load switching of digital processors, EPC for pulsating load of iRAFS, EPC for Modulators, high power EPCs for 250 W SSPAs etc.</p> <p>New EPC development emphasizing the high frequency miniaturized EPCs, advance noise mitigation techniques in compact footprint of EPC, very low voltage (~0.8V) and high peak current EPCs for digital processors, efficient very low noise modular supply for digital devices. to meet the requirement of subsystems of upcoming digitized SDR, HTS and LEOCOM communication payloads.</p>
A10.2		<p>GaN FET based EPCs (SAC)</p> <p>Wide bandgap semiconductors such as the Gallium Nitride (GaN), and Silicon Carbide (SiC) are promising transistor technologies for future generations of power electronics</p>